

PARTS LIST						
ITEM	QTY	PART NUMBER	DESCRIPTION	MATERIAL	LENGTH	WIDTH
1	3	Frame 5		ANG 1000x1000x125	23.188 in	
2	6	Frame 6		ANG 1000x1000x125	65.000 in	
3	3	Roof Sheet 1		EXP 0500-13 FL	67.000 in	48.375 in
4	1	Roof Sheet 3		EXP 0500-13 FL	67.000 in	24.000 in
5	1	Frame 3		HSS 1000x1000x125	65.000 in	
6	2	Frame 1		HSS 1250x1250x125	143.563 in	
7	1	Frame 2		HSS 1250x1250x125	67.500 in	
8	2	Frame 4		HSS 1250x1250x125	24.250 in	
9	5	Lid Guide		PLA 0125	6.000 in	2.960 in
10	1	Chain Holder S		PLA 0188	2.750 in	2.000 in
11	1	Fork Plate		PLA 0250	52.000 in	5.500 in
12	2	Chain .375in (6L)		Purchase (STL)	8.250 in	

EXP 1/2" x 13 FLAT

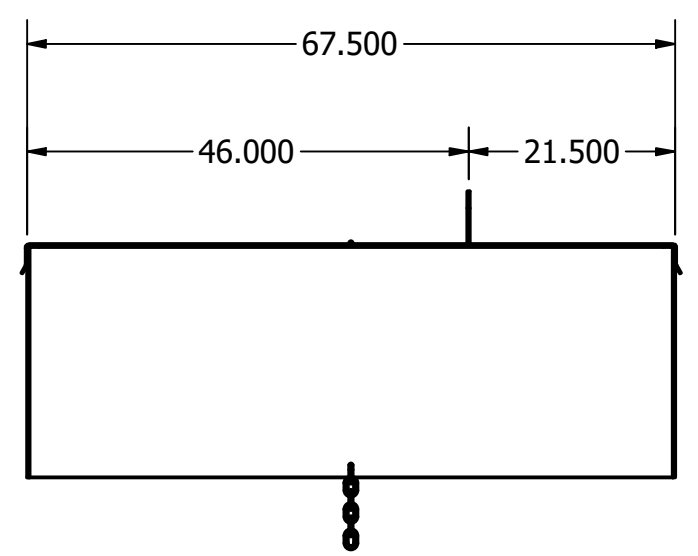

FLARED ALIGNMENT TABS
HSS1.250x1.250

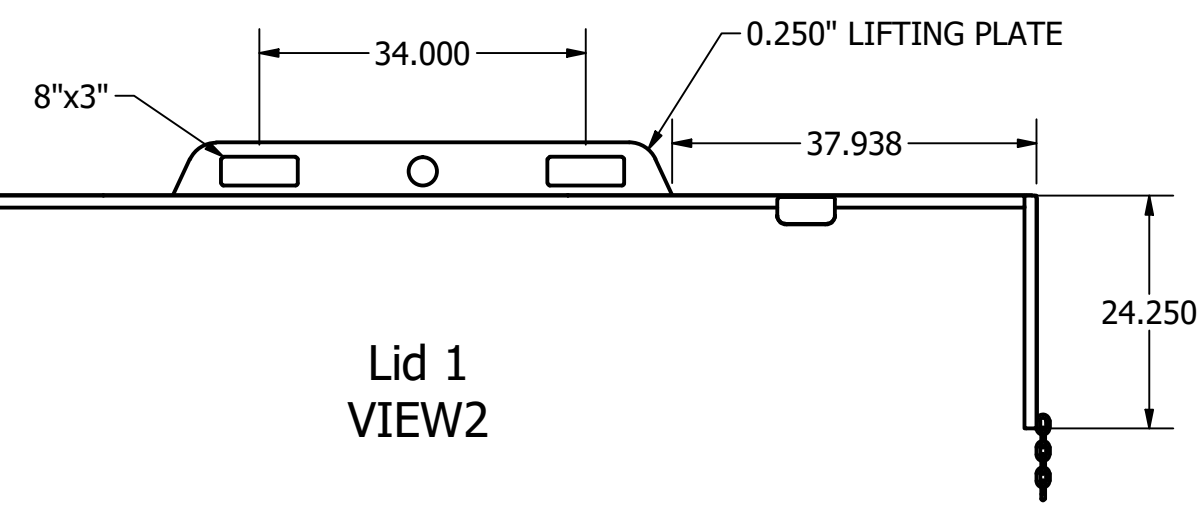
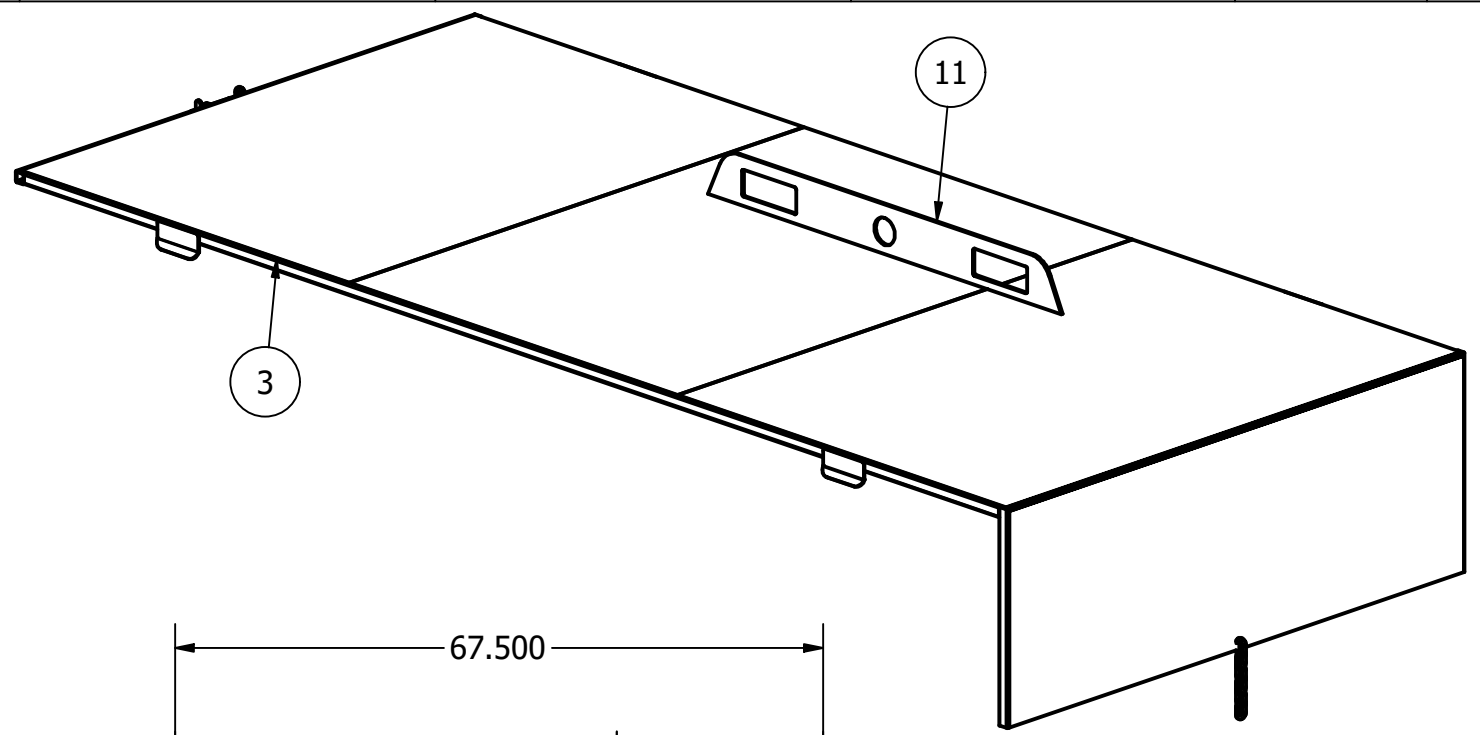
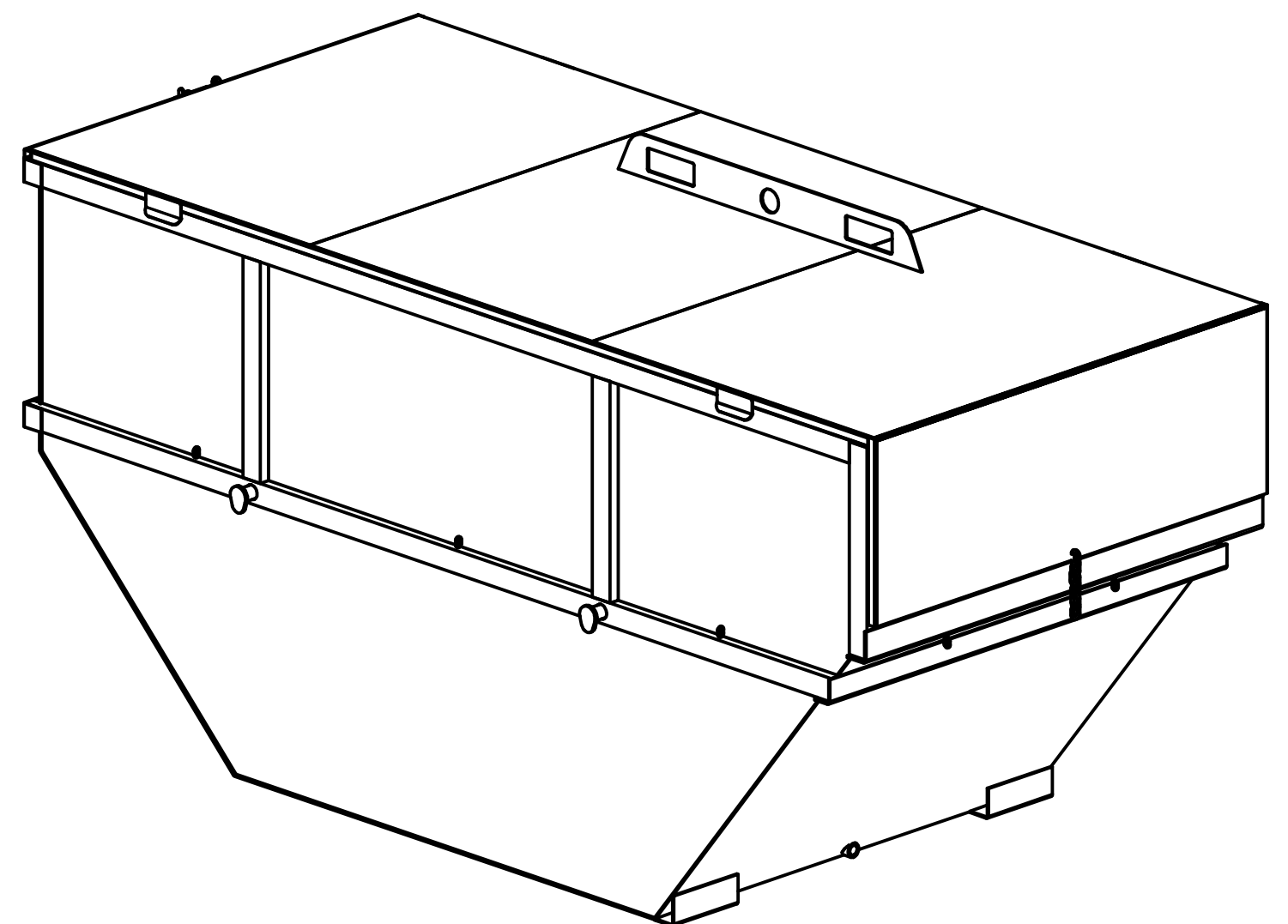
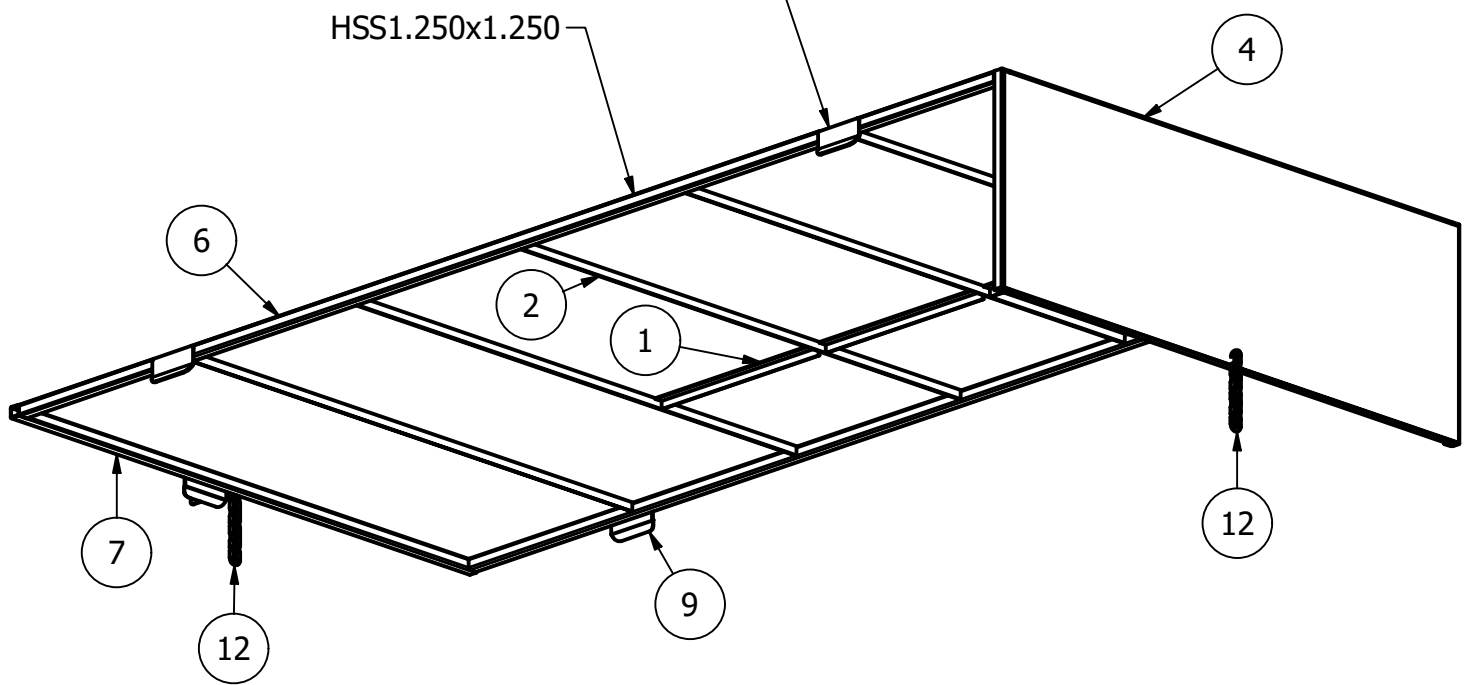

FUSION WEST MANUFACTURING

THIS DRAWING IS THE PROPERTY OF FUSION WEST MANUFACTURING AND CAN NOT BE USED OR COPIED IN WHOLE OR PART WITHOUT PRIOR WRITTEN CONSENT.		Part Name		Size
		Lid 1		
		Material		Sheet
		Sub Assembly		
Part By	Date	Part Description		
GWK	03/31/2023			C
Print By	Date	Drawing Name		Sheet
GWK	03/31/2023	SS-LUG-12Y-STD-DL.idw		1 of 1