

- 3/16" WALLS PANELS
- 11GA REAR UPRIGHTS
- 11GA BODY UPRIGHTS
- 1/4" FLOOR & DOG HOUSE
- 3" CHANNEL FLOOR 16 O/C
- 2"X6"X1/4" TUBE SKIDS
- 3/8" FLAT BAR SKID CAP
- 4"X3"X3/16" TOP RAILS
- 4"X3"X3/16" DOOR FRAME
- LOAD BINDER LOCK, 2x5PC HINGE
- ADDED WALL STIFFENER (pass side)
- ADDED TIE-IN AT HOOK & PLATE
- GREASEABLE 8"X10" HD RR RLR
- GREASEABLE 4"X6" FR RLR w/TIE-IN
- CABLE TYPE LIFT SYST
- CLEAR THROUGH TUNNEL

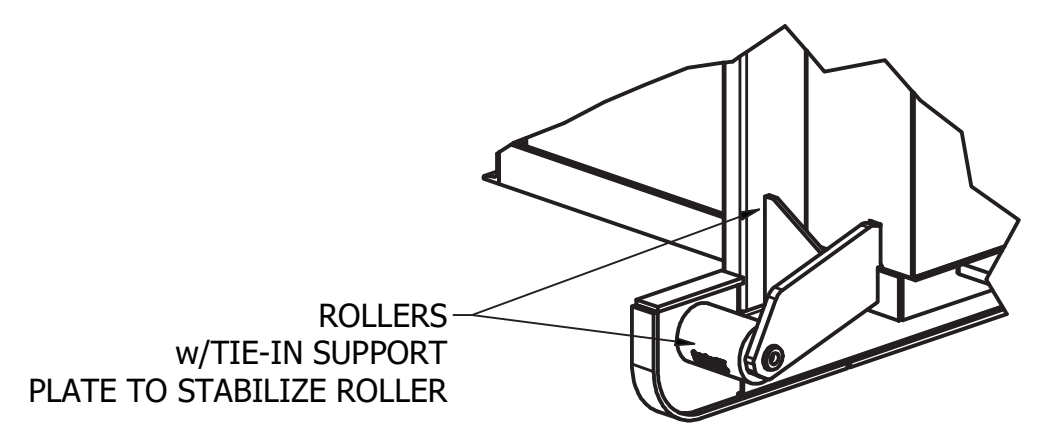

DETAIL D
SCALE .08

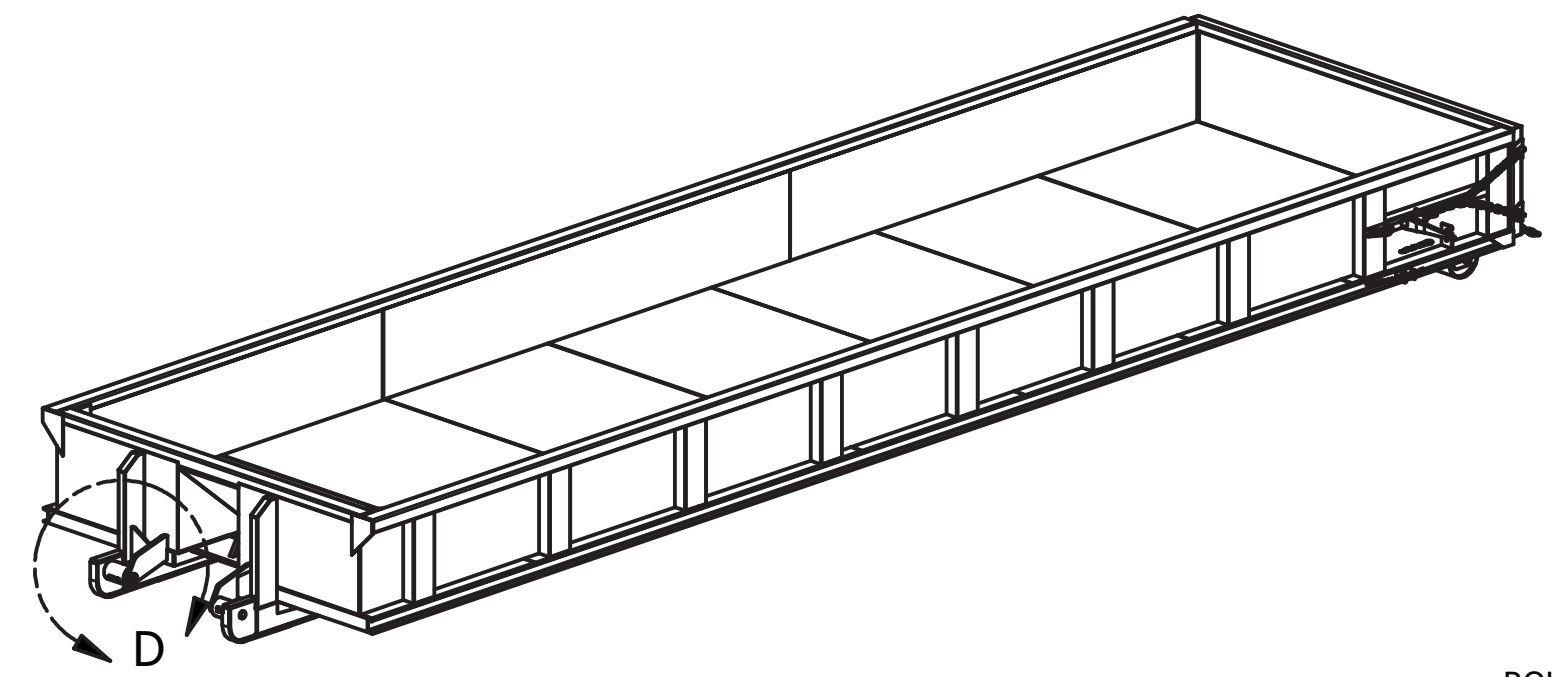
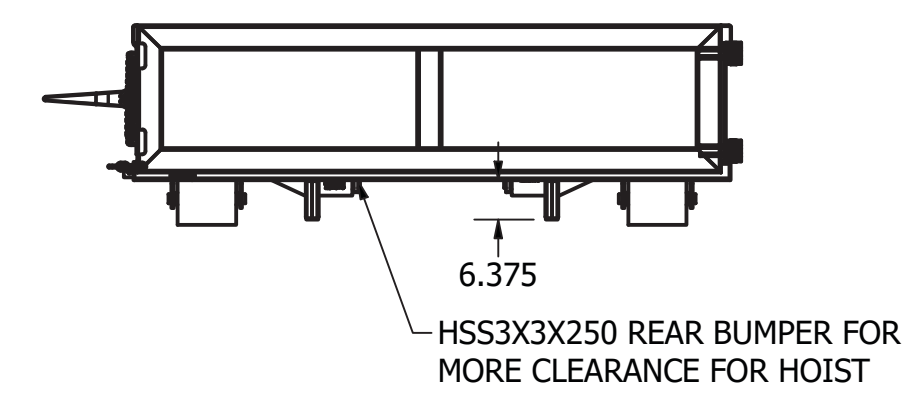
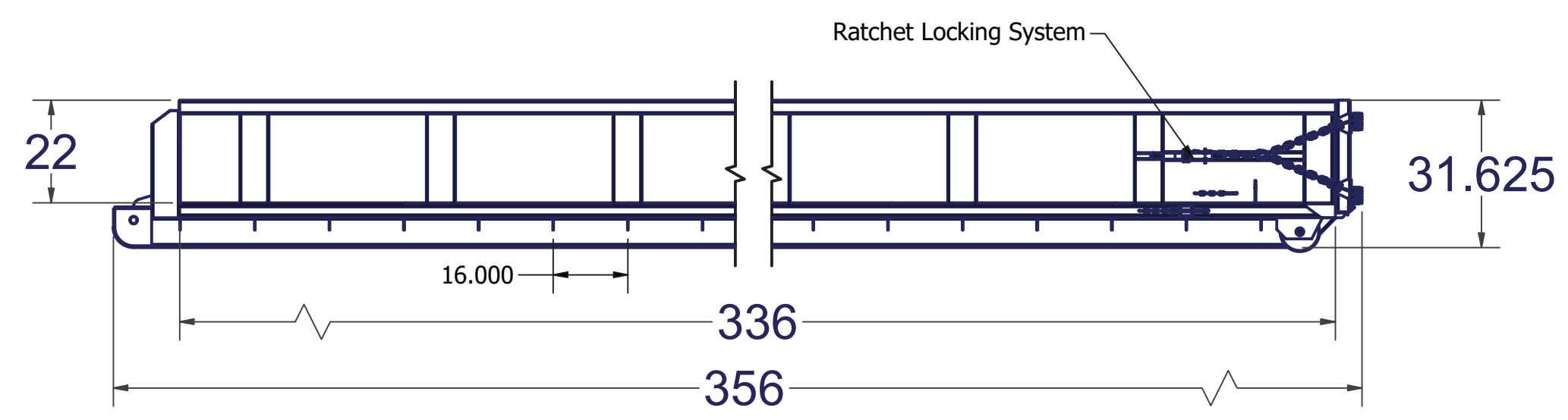
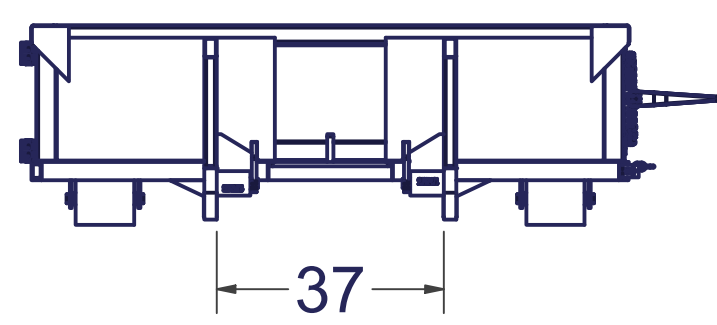
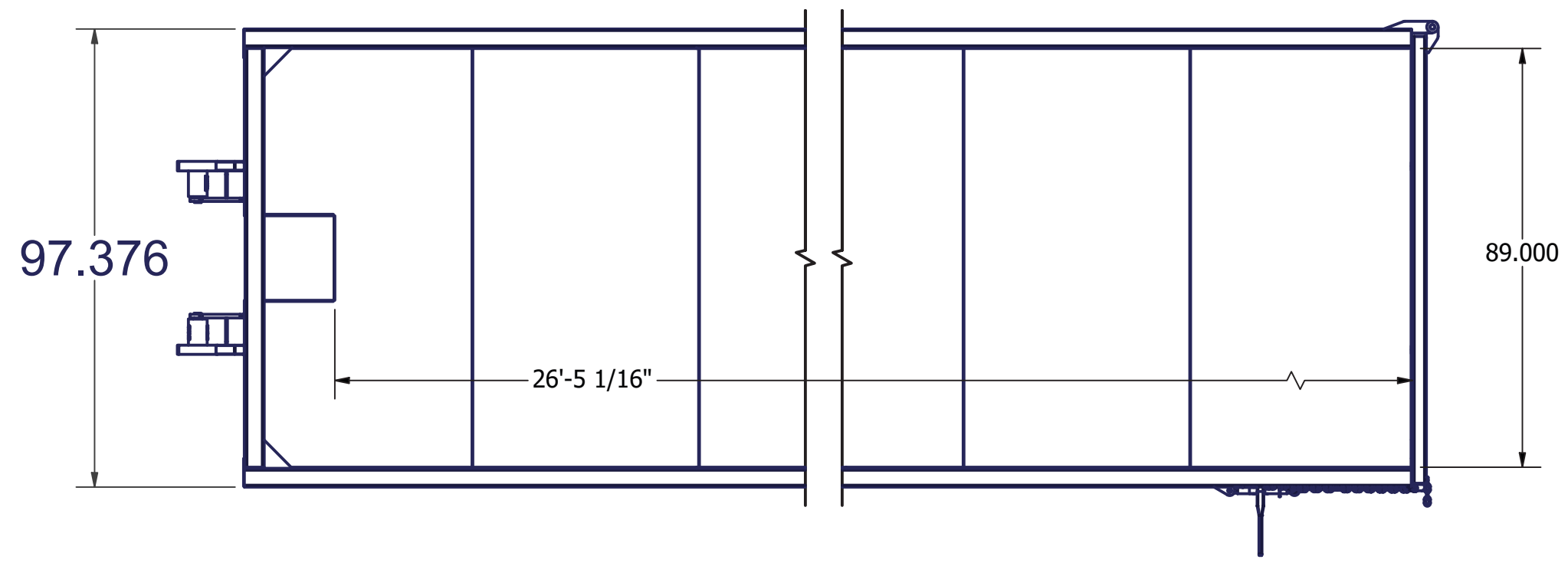

**INLAND STEEL
PRODUCTS**

- 3/16" WALLS PANELS
- 11GA BODY UPRIGHTS
- 11GA REAR UPRIGHTS
- 3/16" FLOOR PLATE
- 3" CHANNEL FLOOR
- 2"X6"X3/16" TUBE SKIDS
- 4"X3"X1/8" TUBE RAILS
- 4"X3"X1/8" DOOR FRAME
- DOOR PIPE 1.5XSCD80
- GREASEABLE 8"X10" HD RR RLR
- GREASEABLE 4"X6" FR RLR w/TIE-IN
- ADDED TIE-IN AT HOOK & PLATE
- CABLE TYPE LIFT SYST
- TARP BARS ALL AROUND
- CLEAR THROUGH TUNNEL

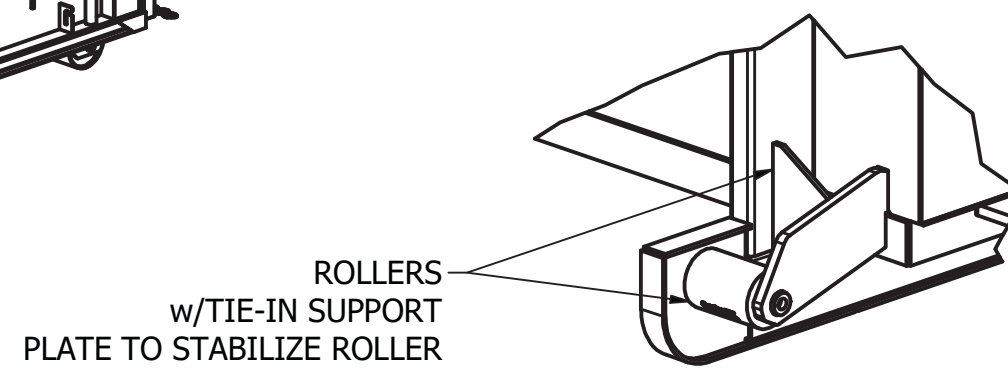
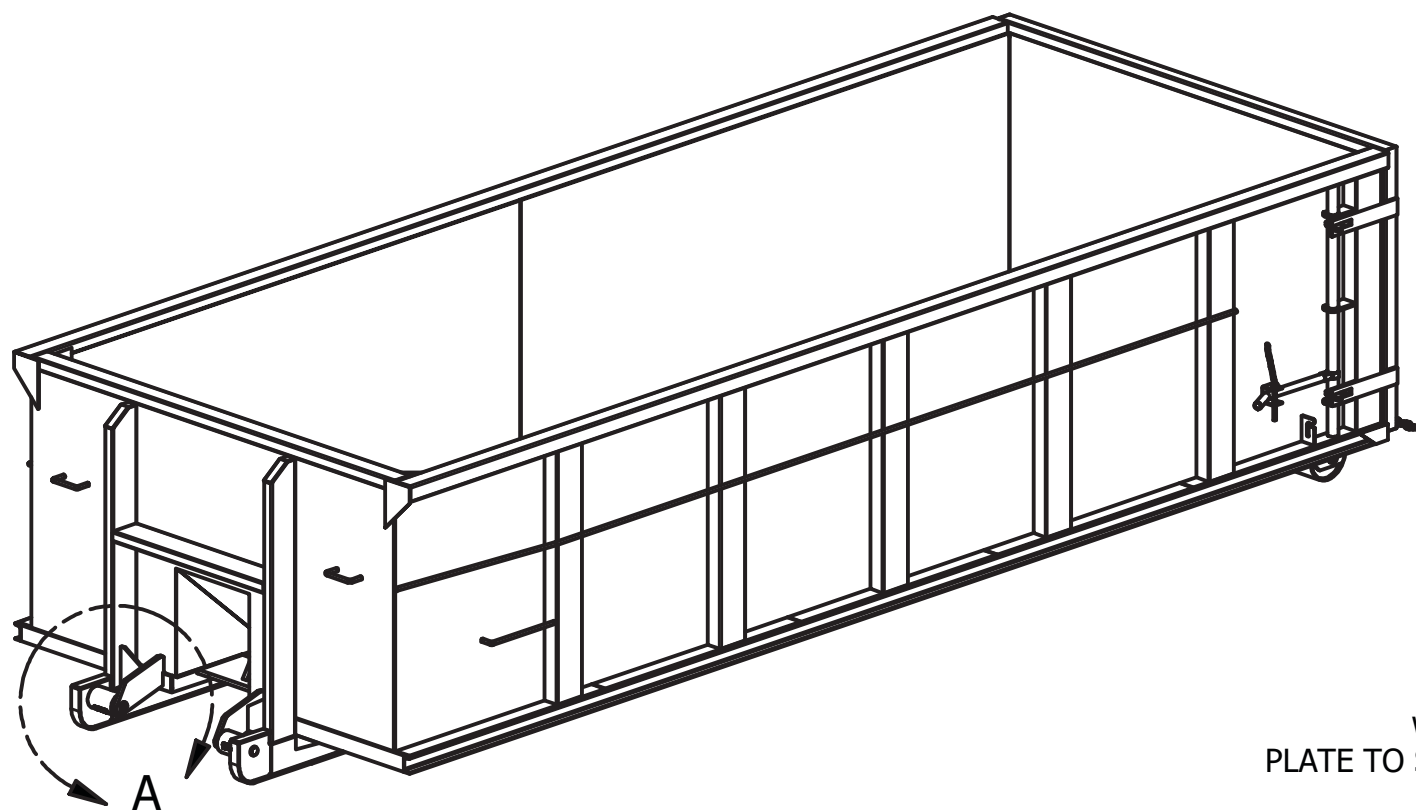
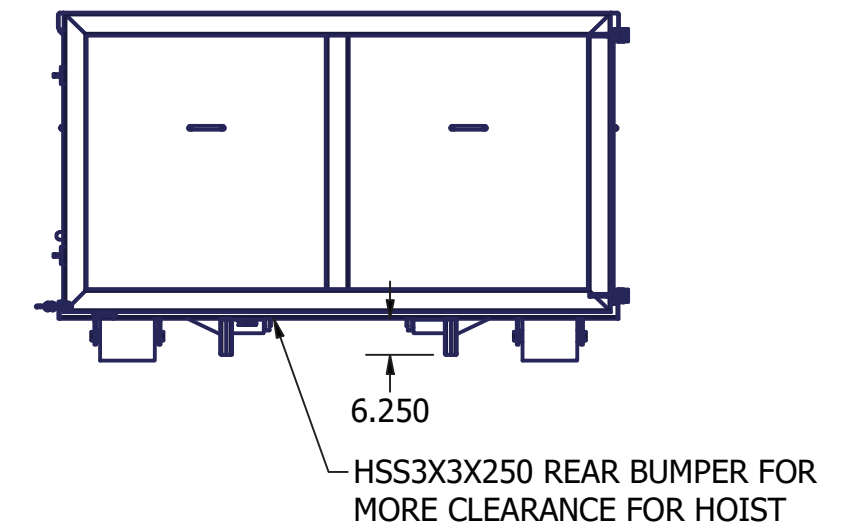
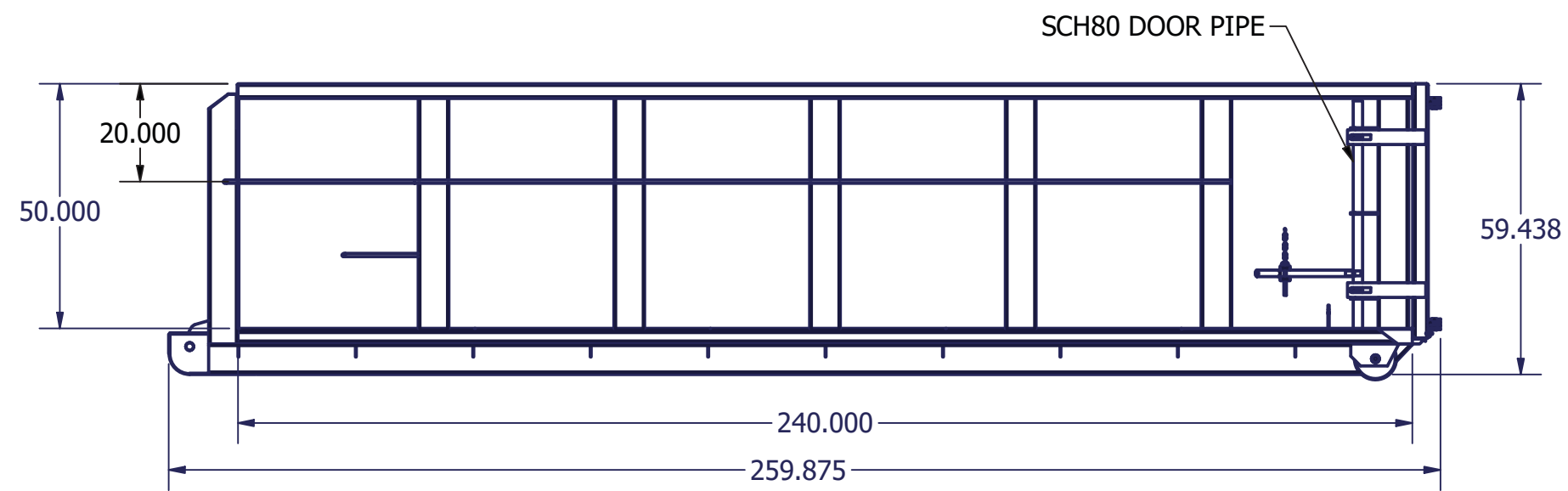
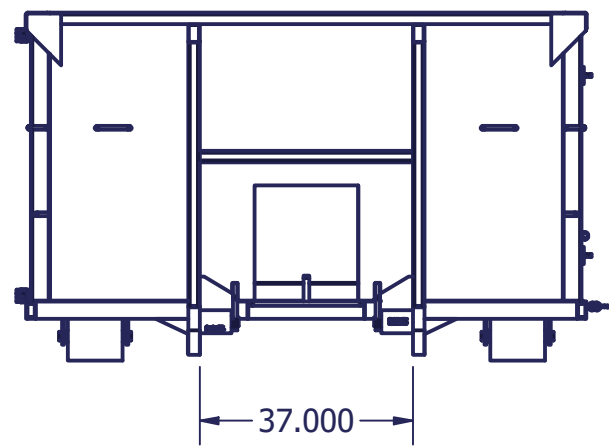
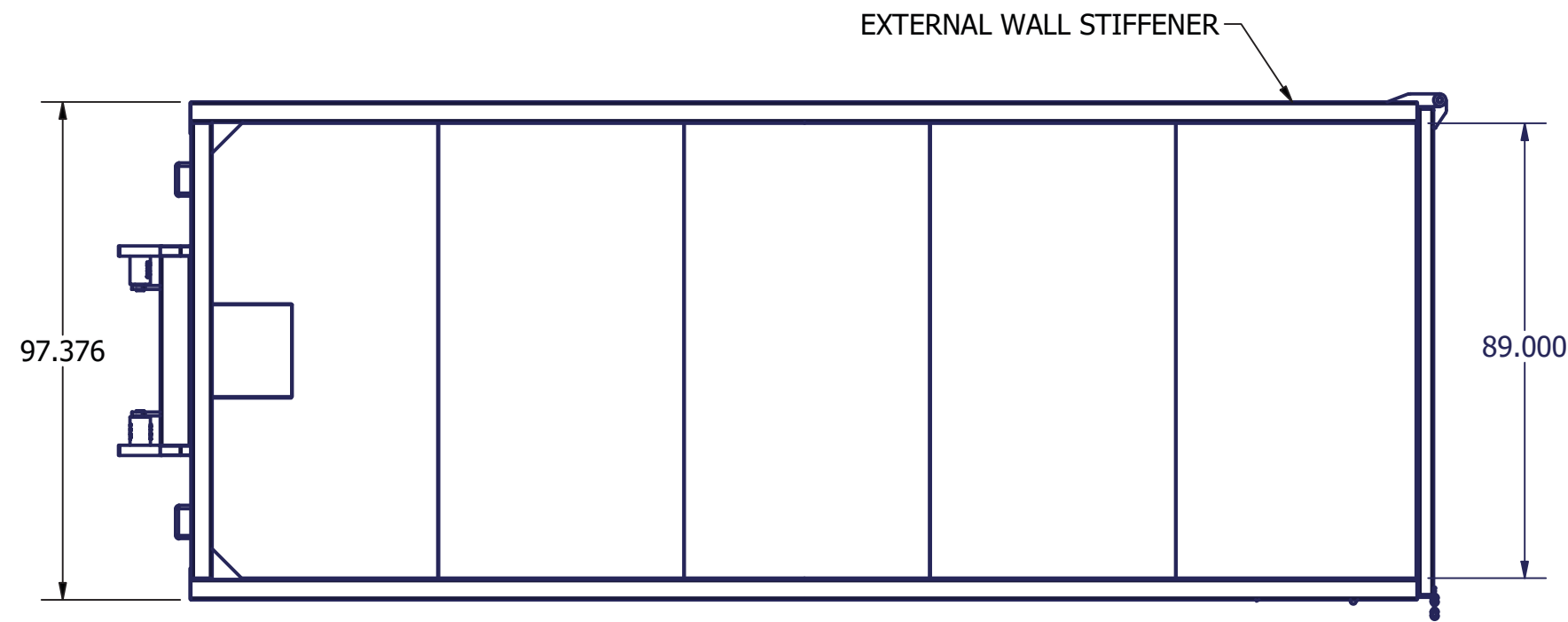

DETAIL A
SCALE .08



**INLAND STEEL
PRODUCTS**

- 3/16" WALLS PANELS
- 11GA BODY UPRIGHTS
- 11GA REAR UPRIGHTS
- 3/16" FLOOR PLATE
- 3" CHANNEL FLOOR
- 2"X6"X3/16" TUBE SKIDS
- 4"X3"X1/8" TUBE RAILS
- 4"X3"X1/8" DOOR FRAME
- GREASEABLE 8"X10" RR RLR
- GREASEABLE 4"X6" FR RLR
- CABLE TYPE LIFT SYST
- TARP BARS ALL AROUND
- CLEAR THROUGH TUNNEL

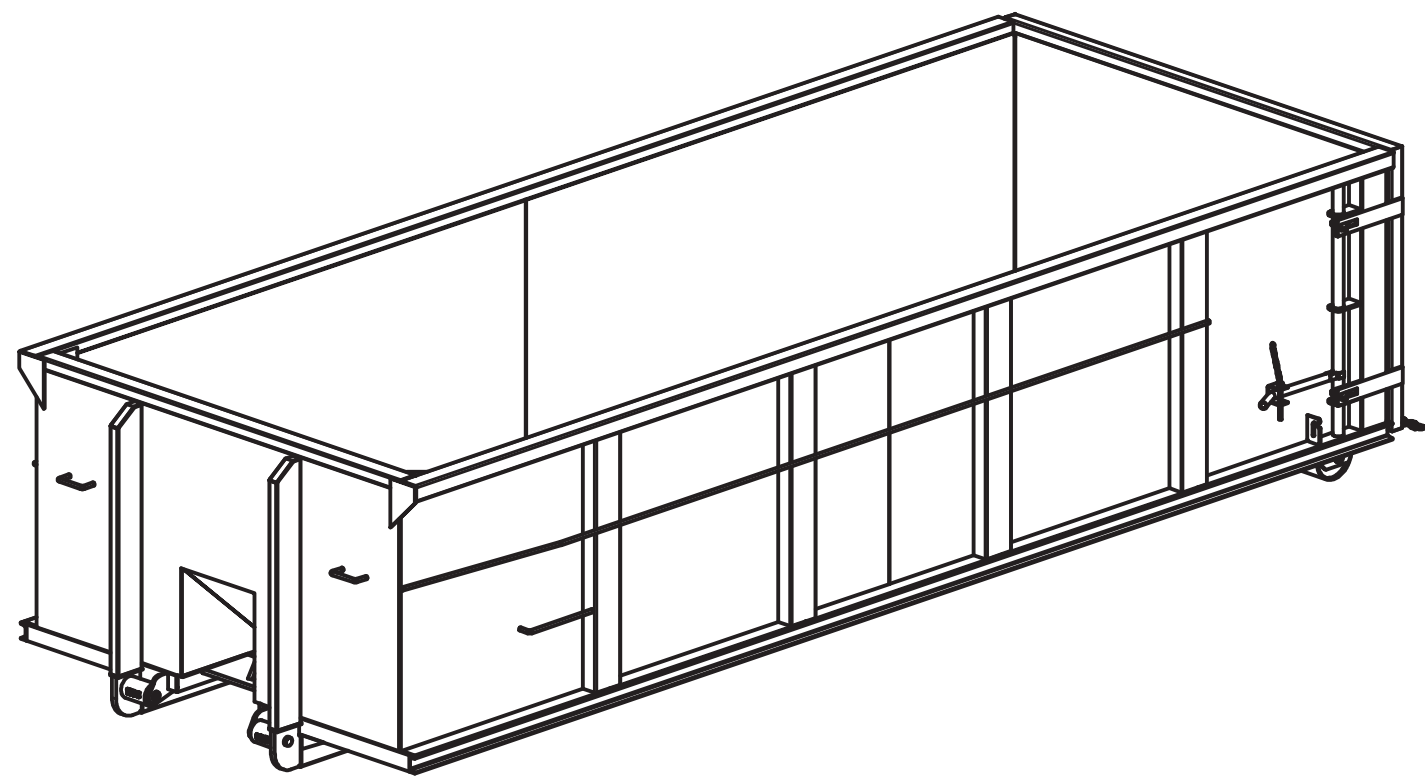
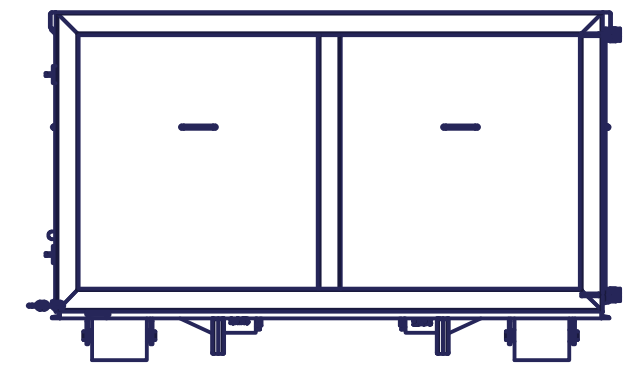
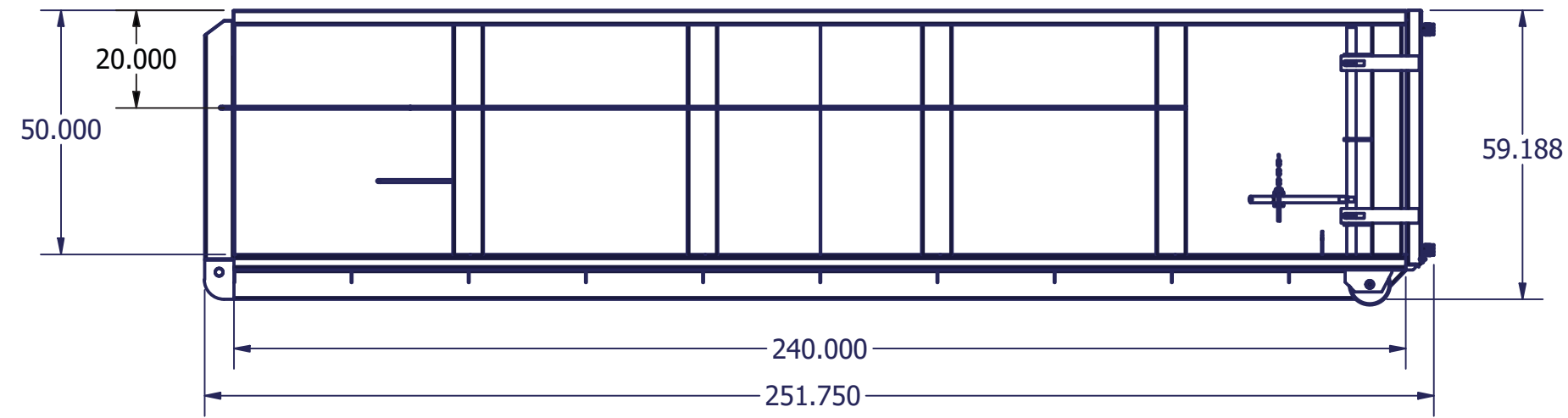
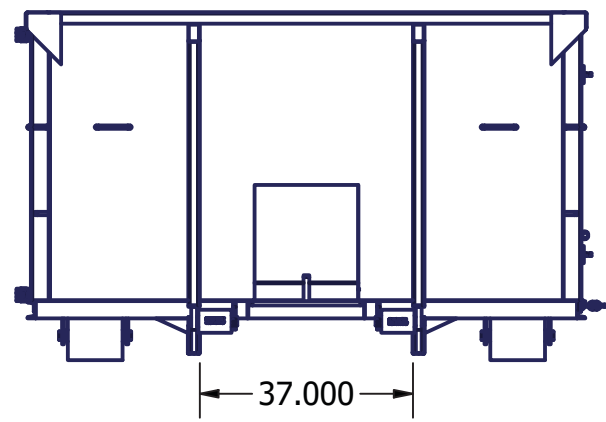
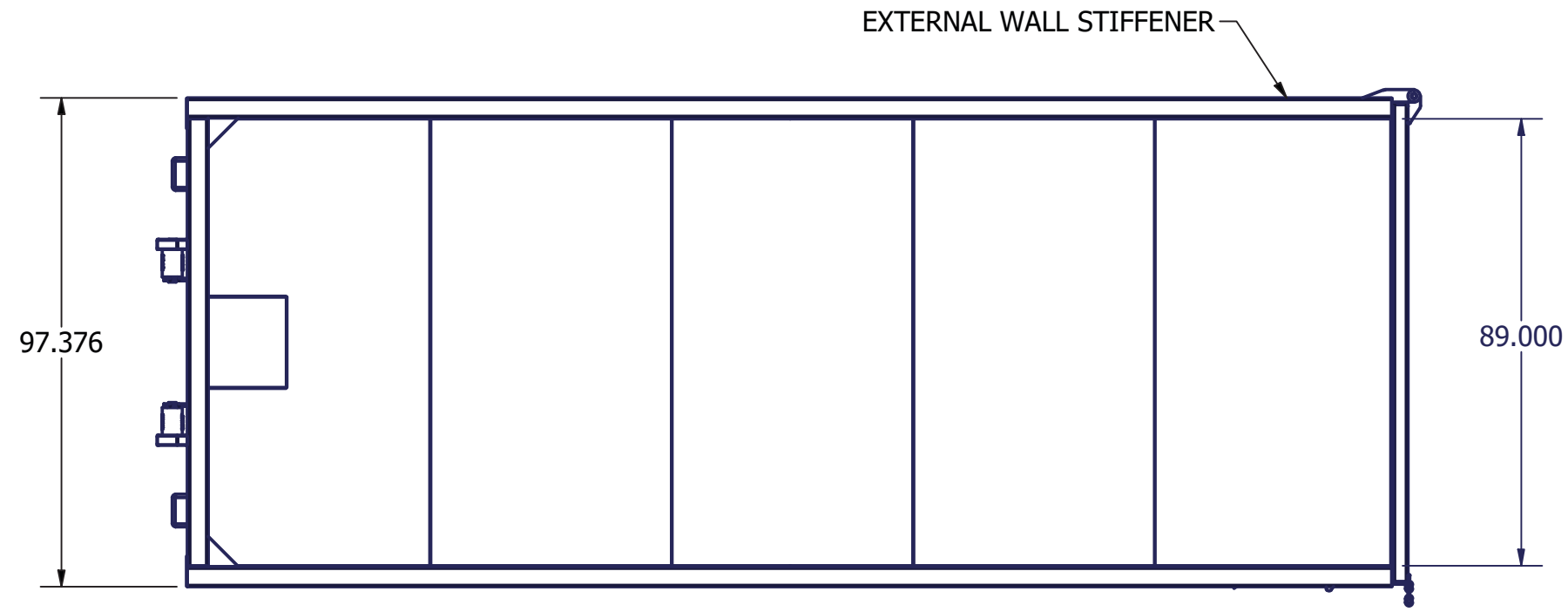

**INLAND STEEL
PRODUCTS**

- 3/16" WALLS PANELS
- 11GA BODY UPRIGHTS
- 11GA REAR UPRIGHTS
- 3/16" FLOOR PLATE
- 3" CHANNEL FLOOR
- FLA 0375X2000 SKINS
- 2"X6"X3/16" TUBE SKIDS
- 4"X3"X3/16" TUBE RAILS
- 4"X3"X3/16" DOOR FRAME
- DOOR PIPE 1.5XSCD80
- GREASEABLE 8"X10" HD RR RLR
- GREASEABLE 4"X6" FR RLR w/TIE-IN
- ADDED TIE-IN AT HOOK & PLATE
- CABLE TYPE LIFT SYST
- TARP BARS ALL AROUND
- CLEAR THROUGH TUNNEL
- 2 - 5PC HINGES

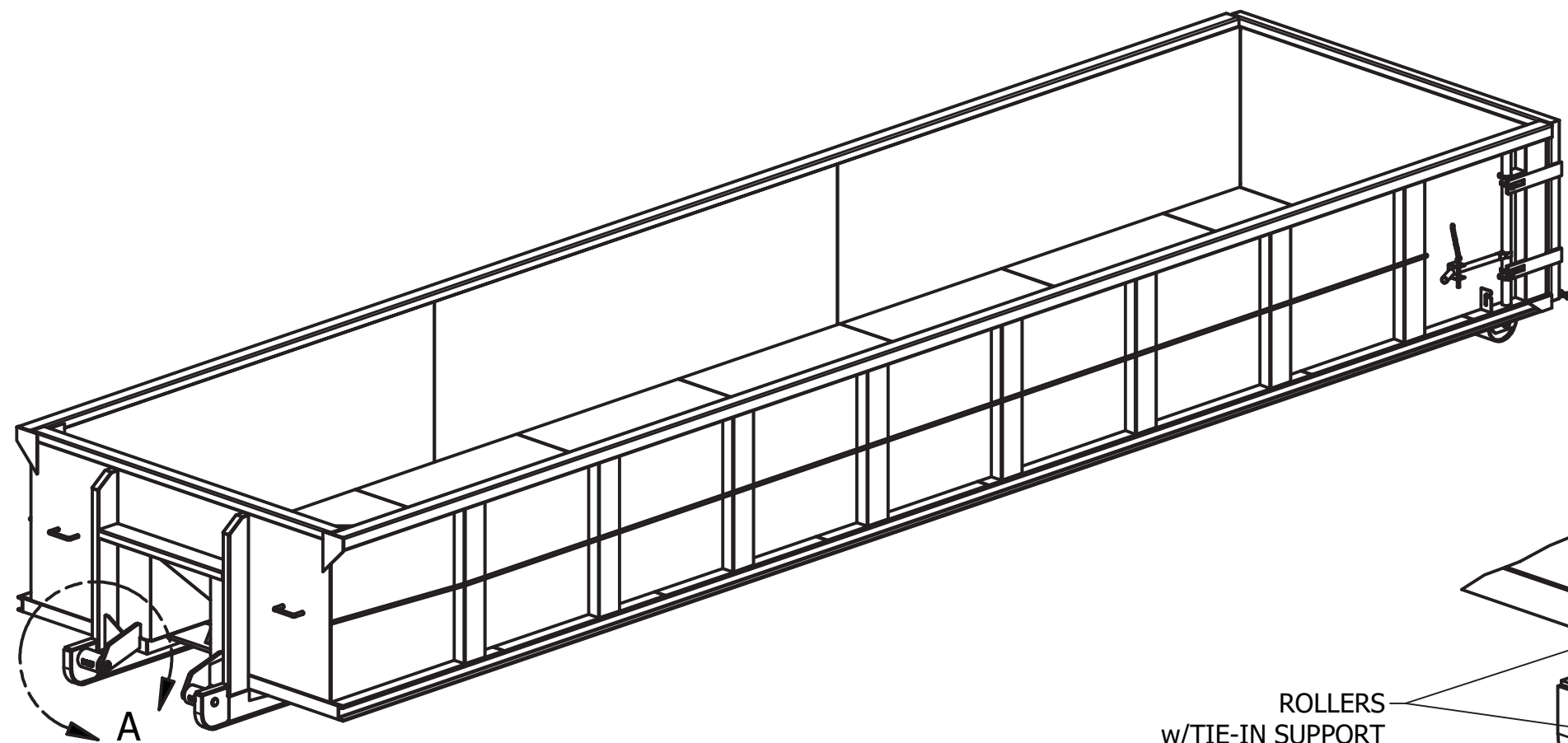
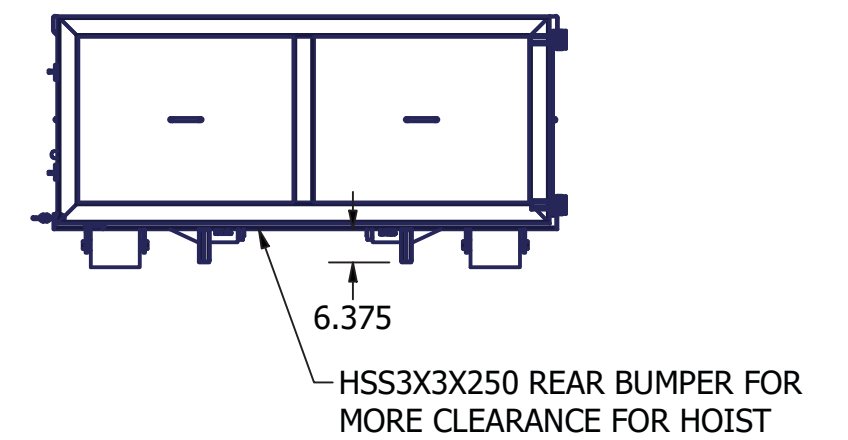
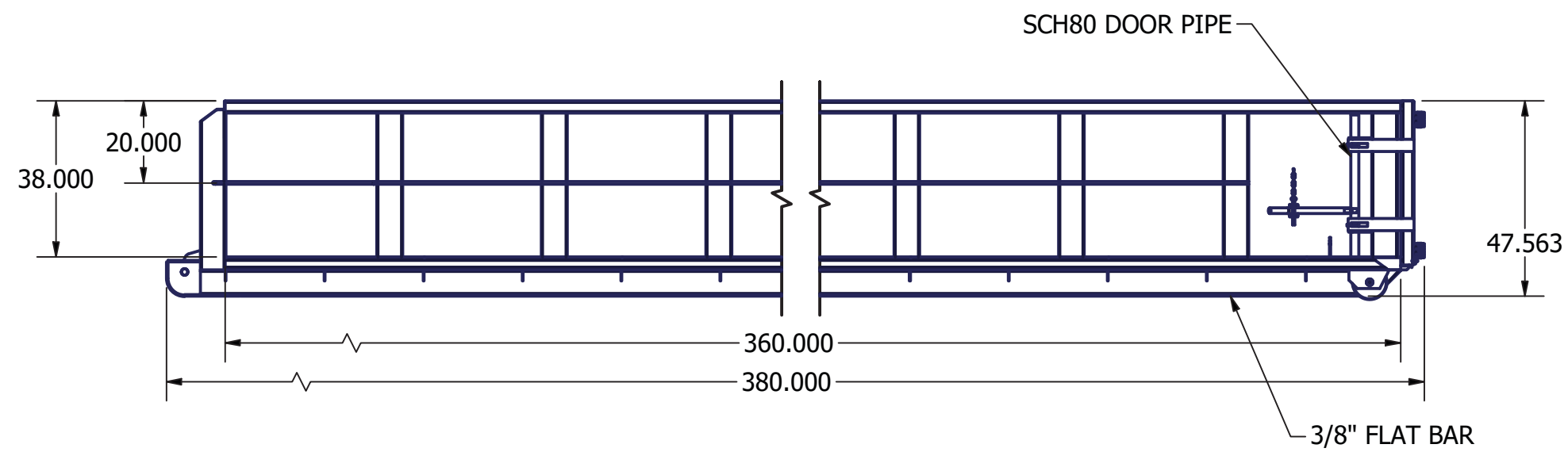
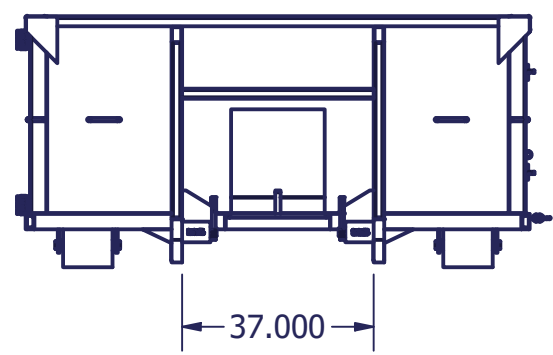
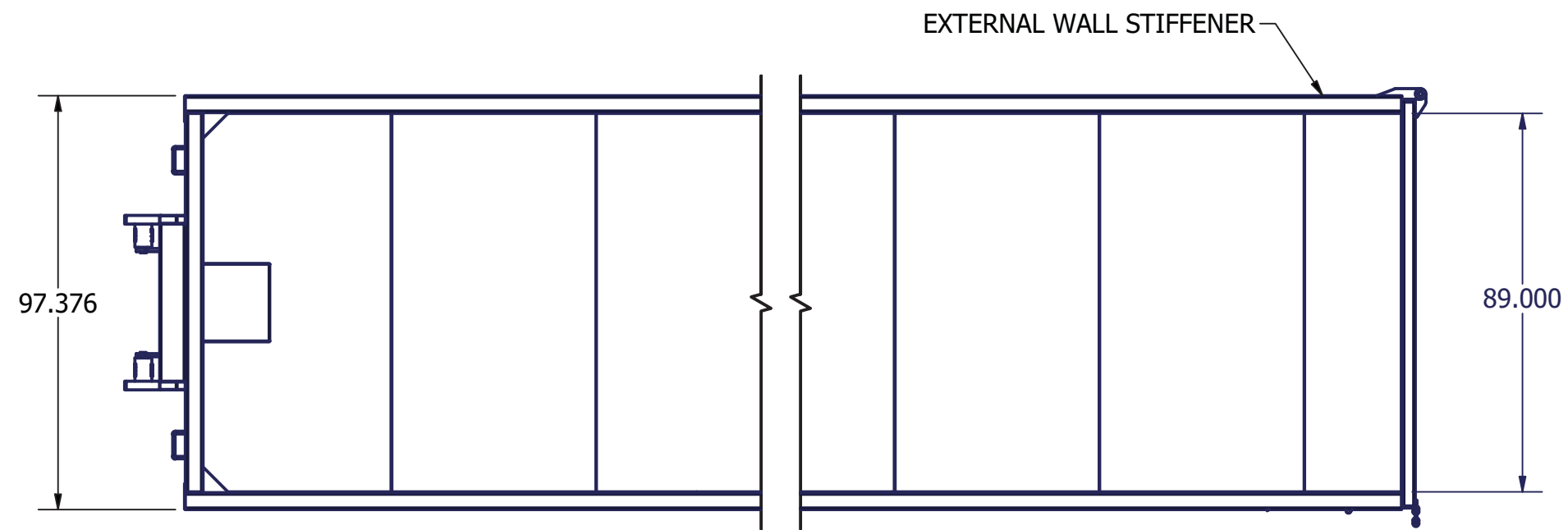

ROLLERS
w/TIE-IN SUPPORT
PLATE TO STABILIZE ROLLER

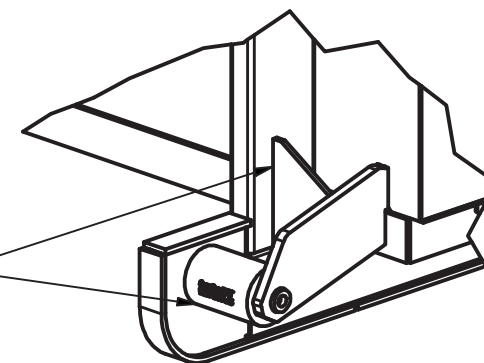

DETAIL A
SCALE .08



**INLAND STEEL
PRODUCTS**

- 3/16" WALLS PANELS
- 11GA BODY UPRIGHTS
- 11GA REAR UPRIGHTS
- 3/16" FLOOR PLATE
- 3" CHANNEL FLOOR
- 2"X6"X3/16" TUBE SKIDS
- 4"X3"X1/8" TUBE RAILS
- 4"X3"X1/8" DOOR FRAME
- DOOR PIPE 1.5XSCD80
- GREASEABLE 8"X10" HD RR RLR
- GREASEABLE 4"X6" FR RLR w/TIE-IN
- ADDED TIE-IN AT HOOK & PLATE
- CABLE TYPE LIFT SYST
- TARP BARS ALL AROUND
- CLEAR THROUGH TUNNEL

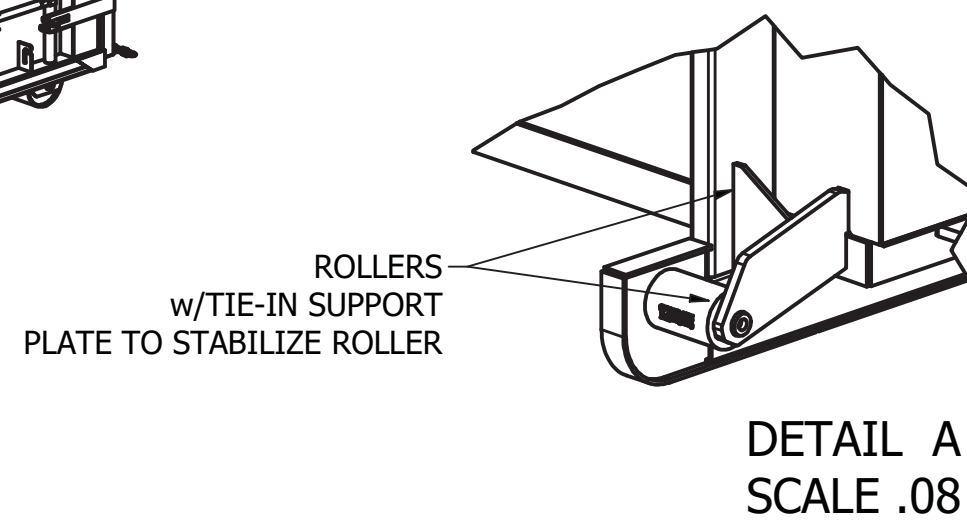
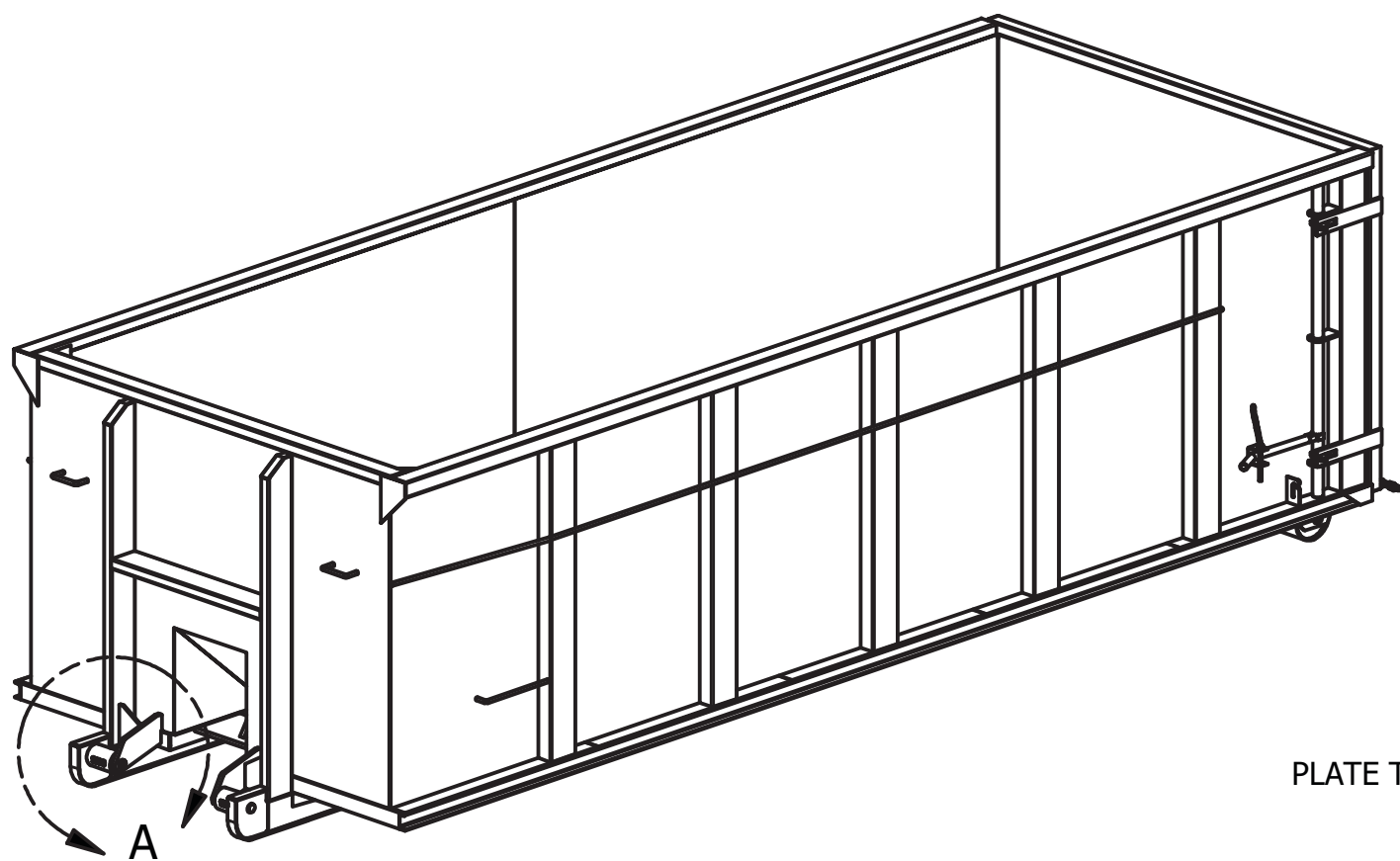
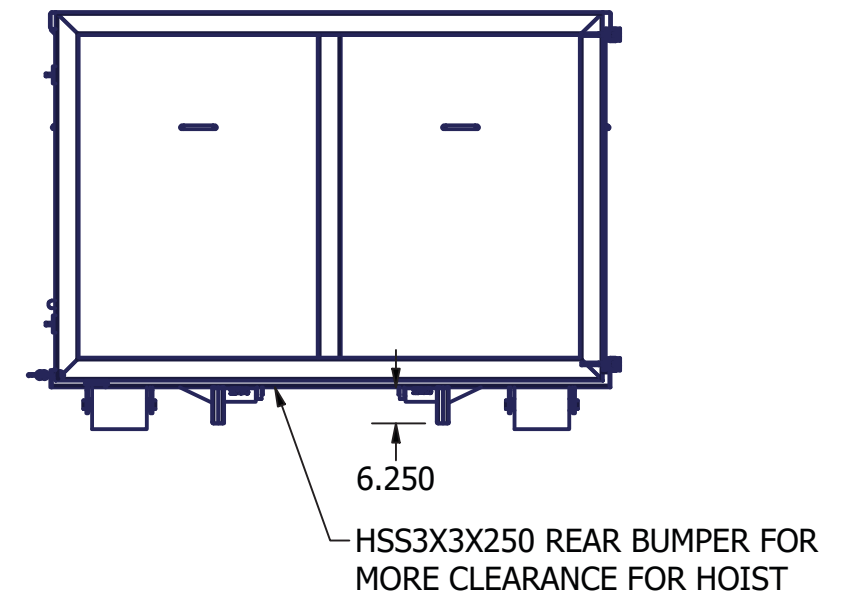
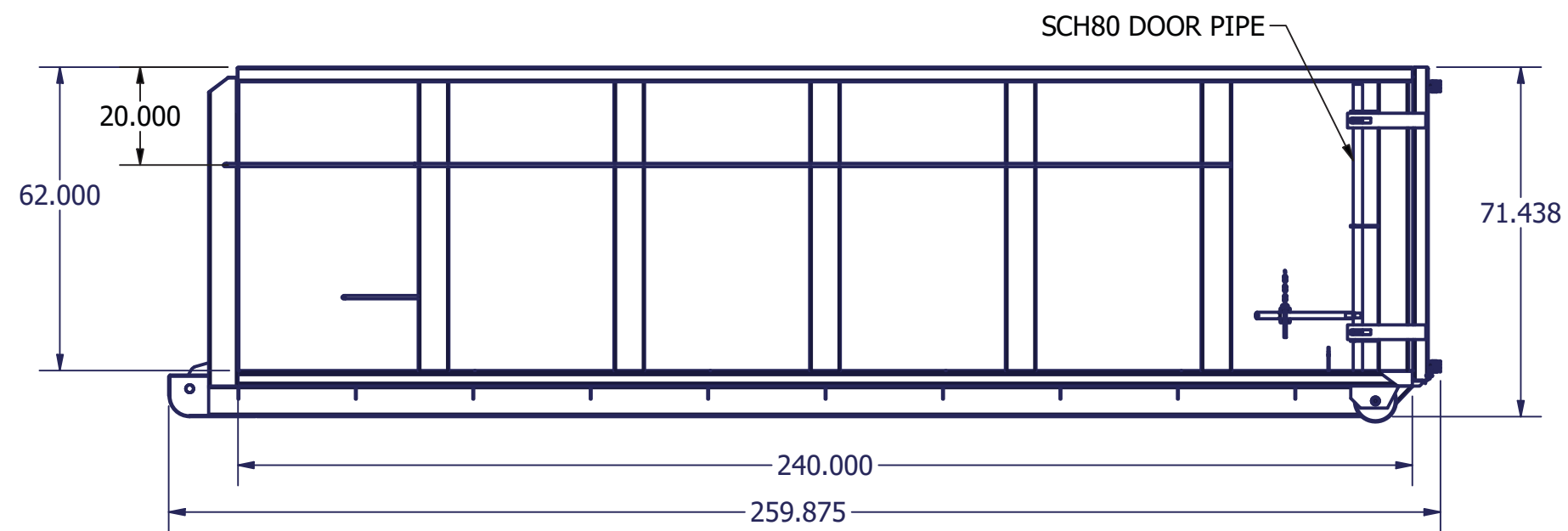
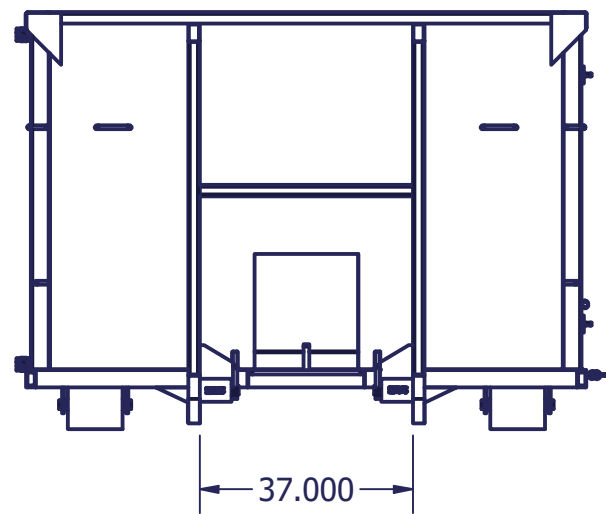
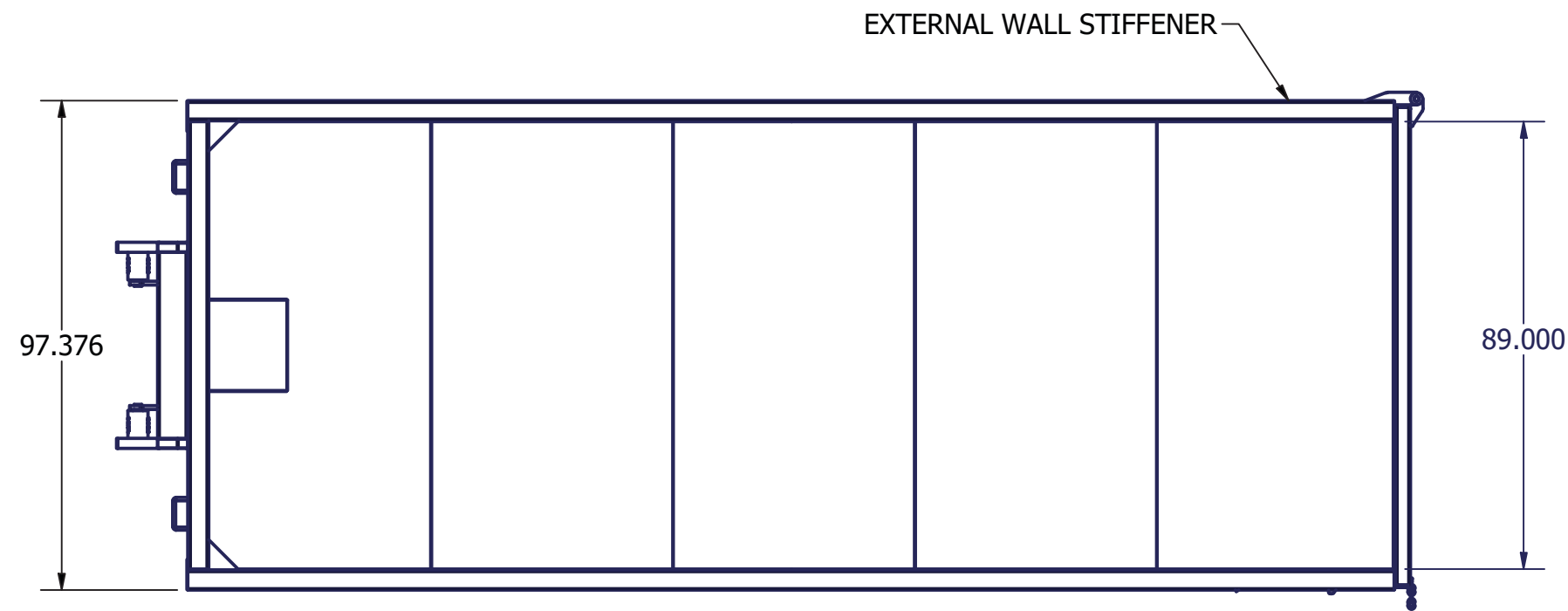

**INLAND STEEL
PRODUCTS**

- 3/16" WALLS PANELS
- 11GA BODY UPRIGHTS
- 11GA REAR UPRIGHTS
- 3/16" FLOOR PLATE
- 3" CHANNEL FLOOR
- 2"X6"X3/16" TUBE SKIDS
- 4"X3"X1/8" TUBE RAILS
- 4"X3"X1/8" DOOR FRAME
- GREASEABLE 8"X10" RR RLR
- GREASEABLE 4"X6" FR RLR
- CABLE TYPE LIFT SYST
- TARP BARS ALL AROUND
- CLEAR THROUGH TUNNEL

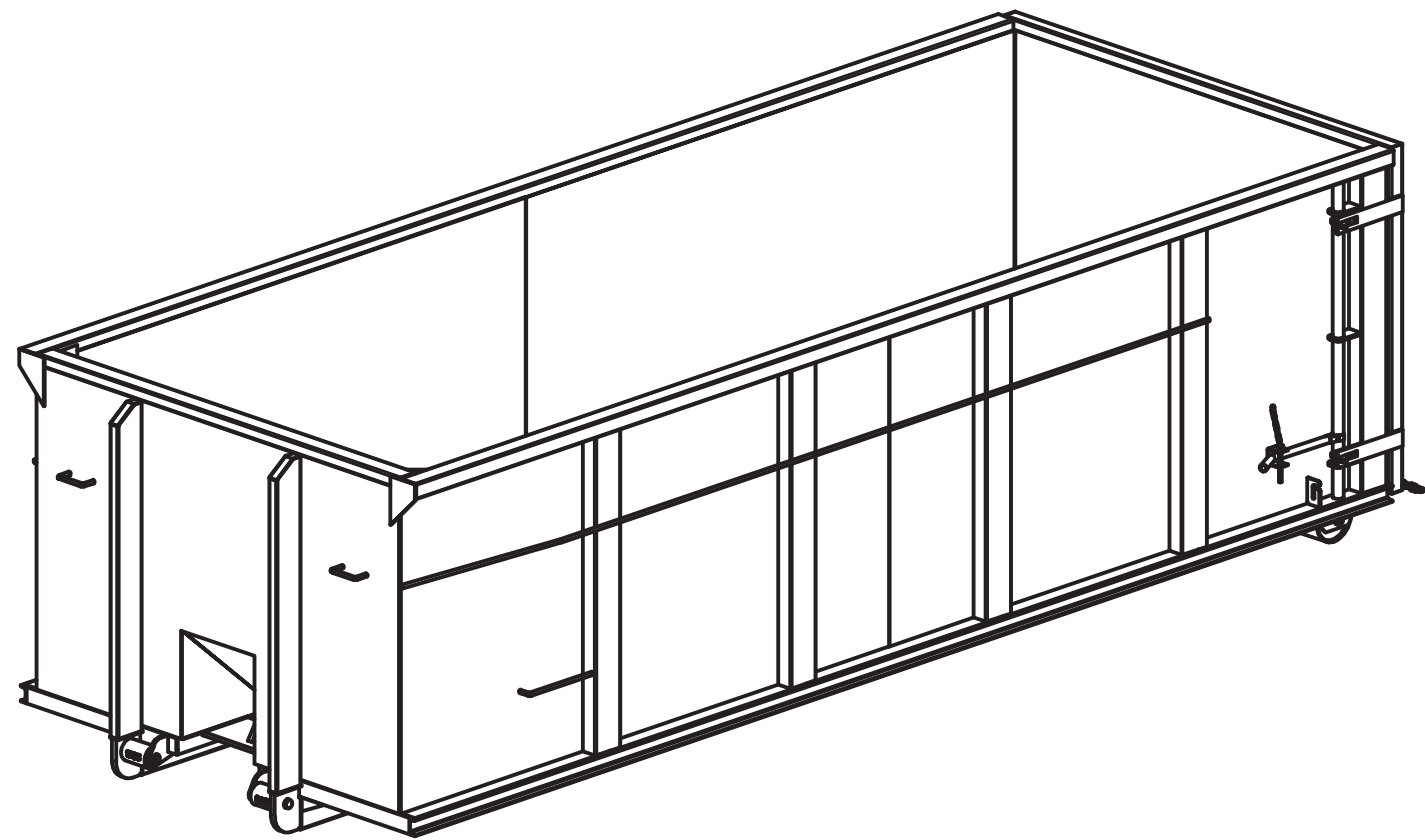
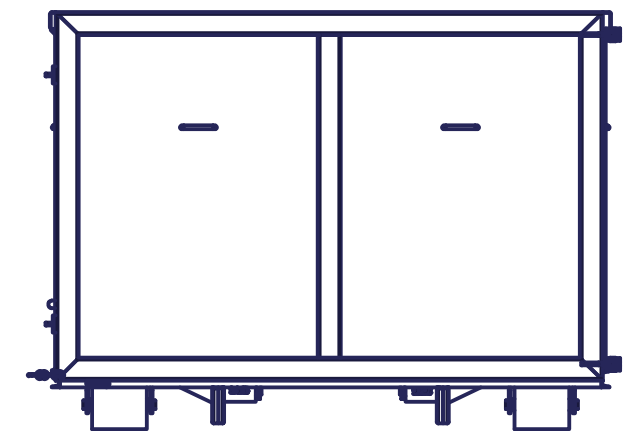
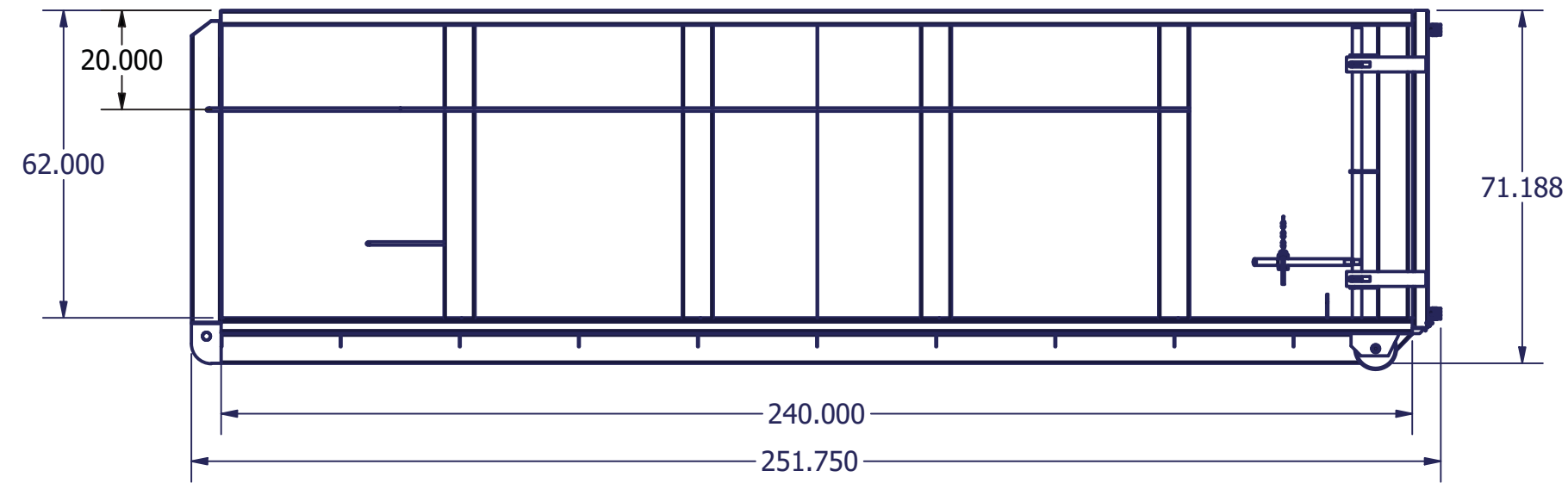
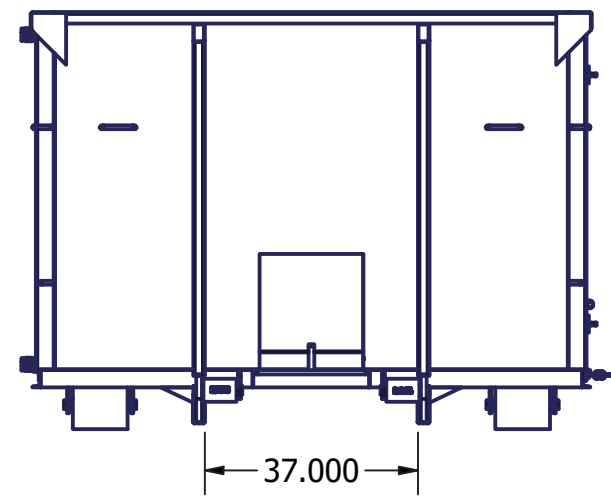
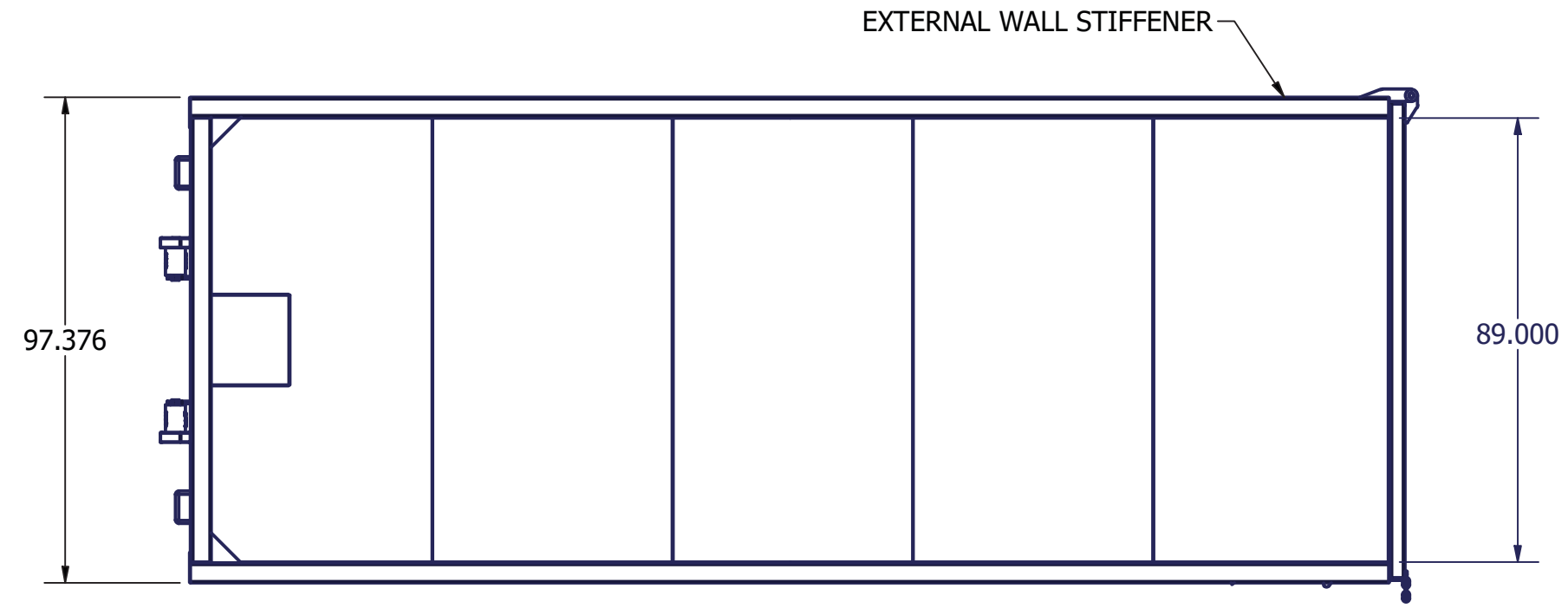

**INLAND STEEL
PRODUCTS**

- 3/16" WALLS PANELS
- 11GA BODY UPRIGHTS
- 11GA REAR UPRIGHTS
- 3/16" FLOOR PLATE
- 3" CHANNEL FLOOR
- FLA 0375X2000 SKINS
- 2"X6"X3/16" TUBE SKIDS
- 4"X3"X3/16" TUBE RAILS
- 4"X3"X3/16" DOOR FRAME
- DOOR PIPE 1.5XSCD80
- GREASEABLE 8"X10" HD RR RLR
- GREASEABLE 4"X6" FR RLR w/TIE-IN
- ADDED TIE-IN AT HOOK & PLATE
- CABLE TYPE LIFT SYST
- TARP BARS ALL AROUND
- CLEAR THROUGH TUNNEL
- 2 - 5PC HINGES

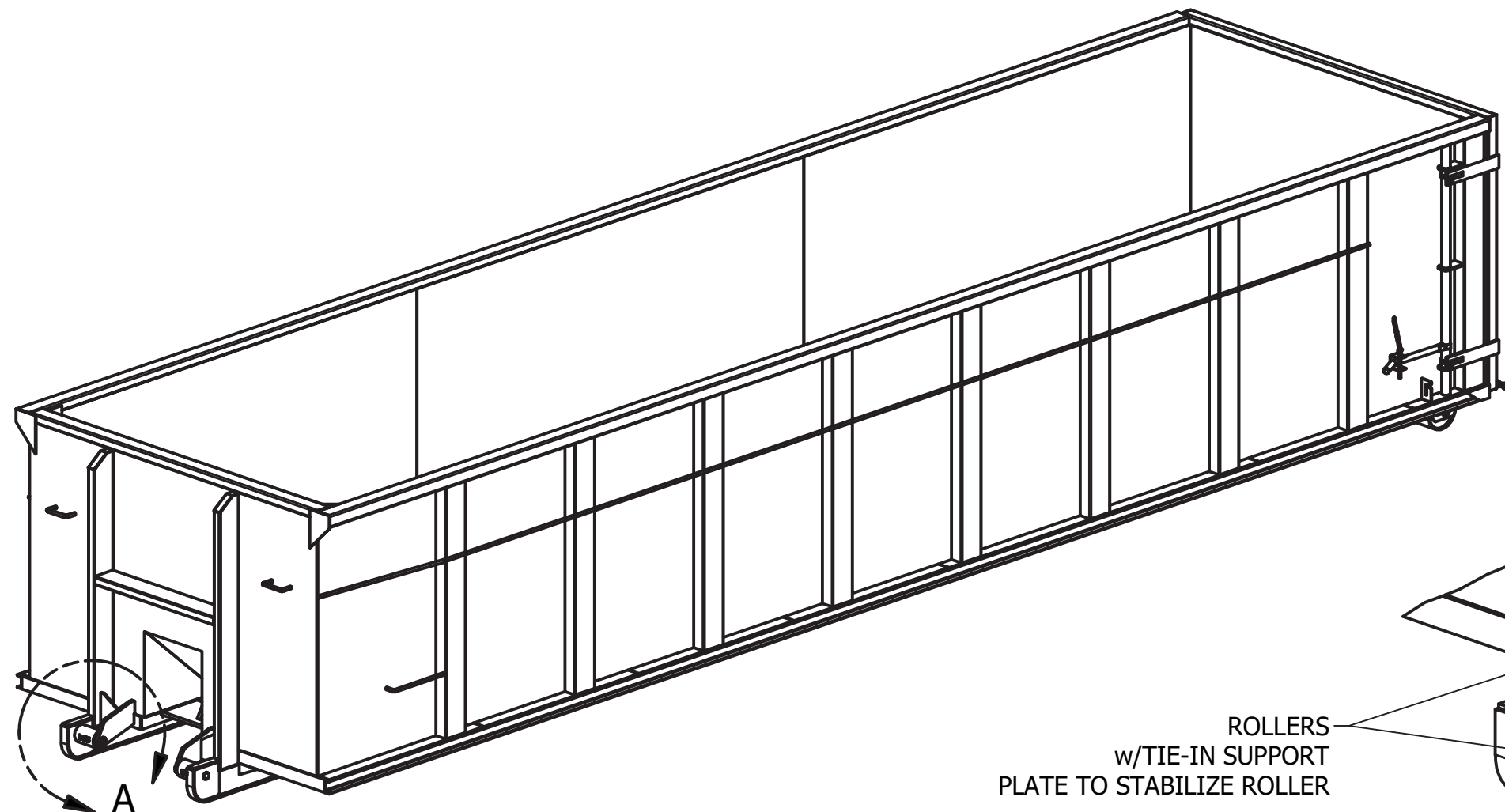
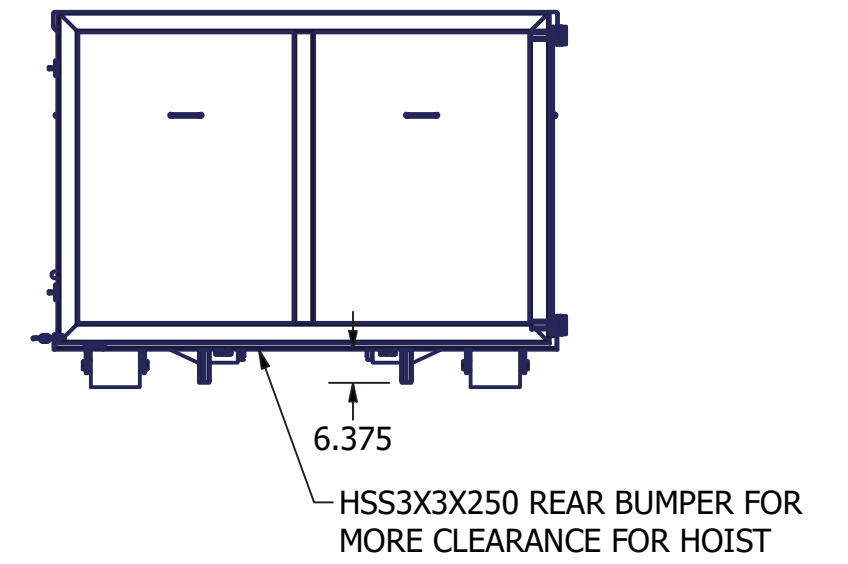
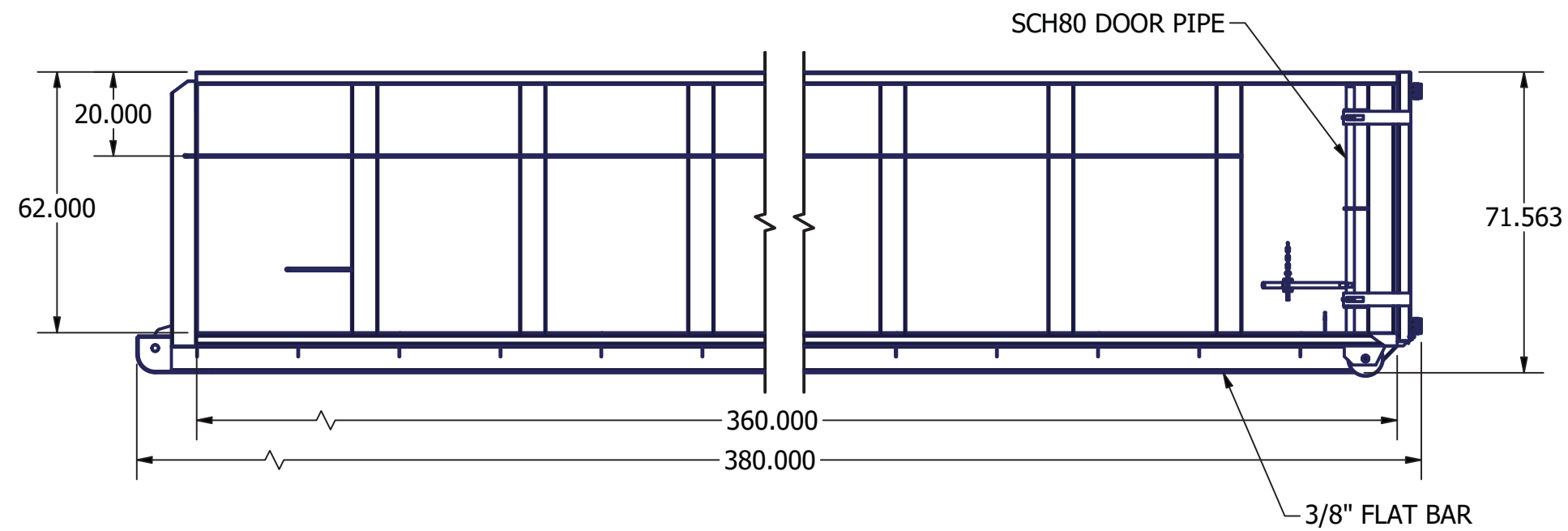
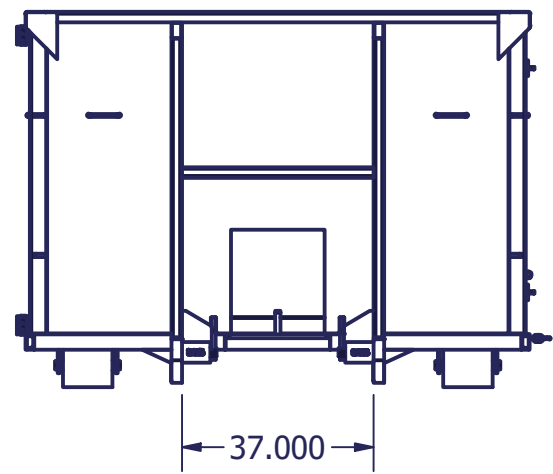
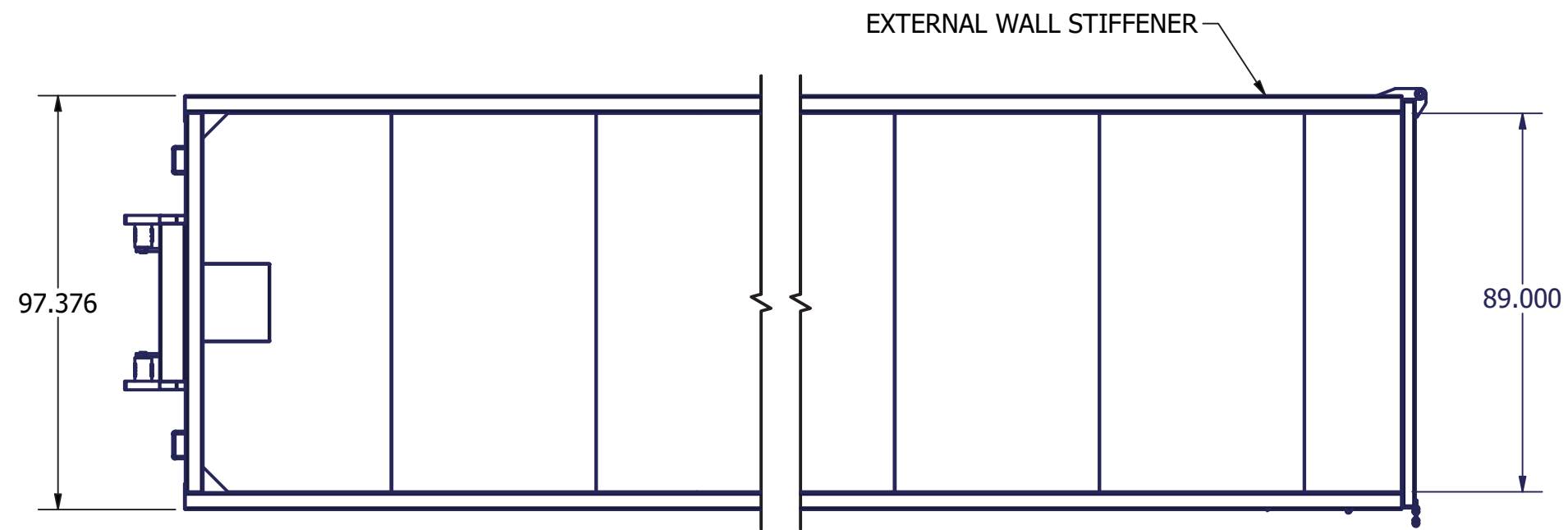

ROLLERS
w/TIE-IN SUPPORT
PLATE TO STABILIZE ROLLER

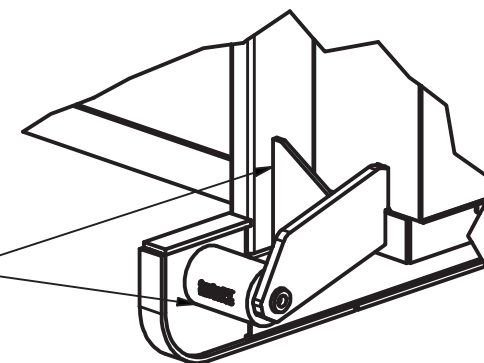

DETAIL A
SCALE .08



**INLAND STEEL
PRODUCTS**

- 3/16" WALLS PANELS
- 11GA BODY UPRIGHTS
- 11GA REAR UPRIGHTS
- 3/16" FLOOR PLATE
- 3" CHANNEL FLOOR
- 2"X6"X3/16" TUBE SKIDS
- 4"X3"X1/8" TUBE RAILS
- 4"X3"X1/8" DOOR FRAME
- GREASEABLE 8"X10" RR RLR
- GREASEABLE 4"X6" FR RLR
- ADDED TIE-IN AT HOOK & PLATE
- CABLE TYPE LIFT SYST
- TARP BARS ALL AROUND
- CLEAR THROUGH TUNNEL

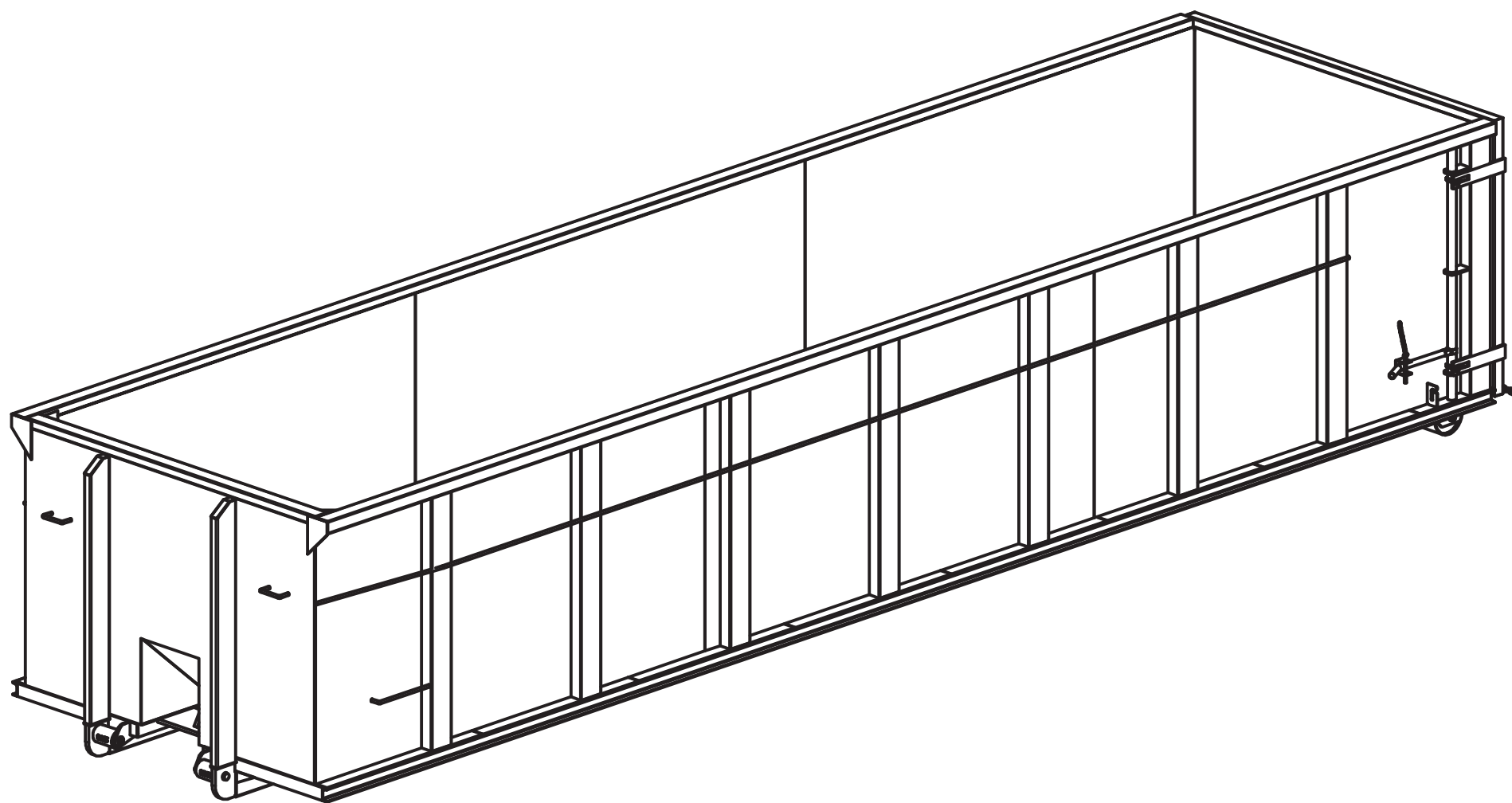
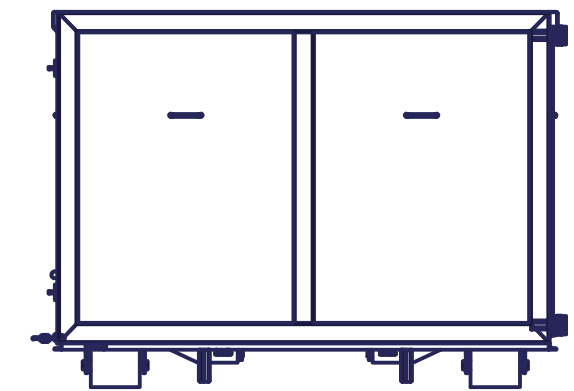
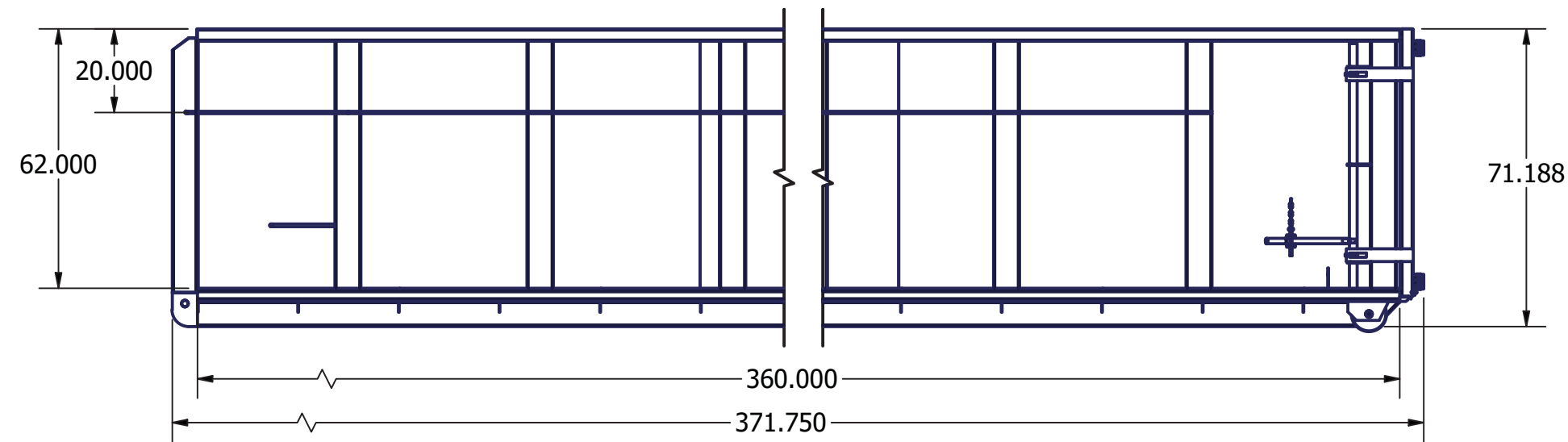
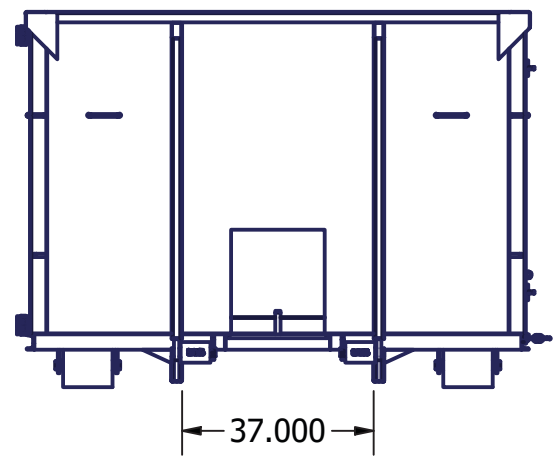
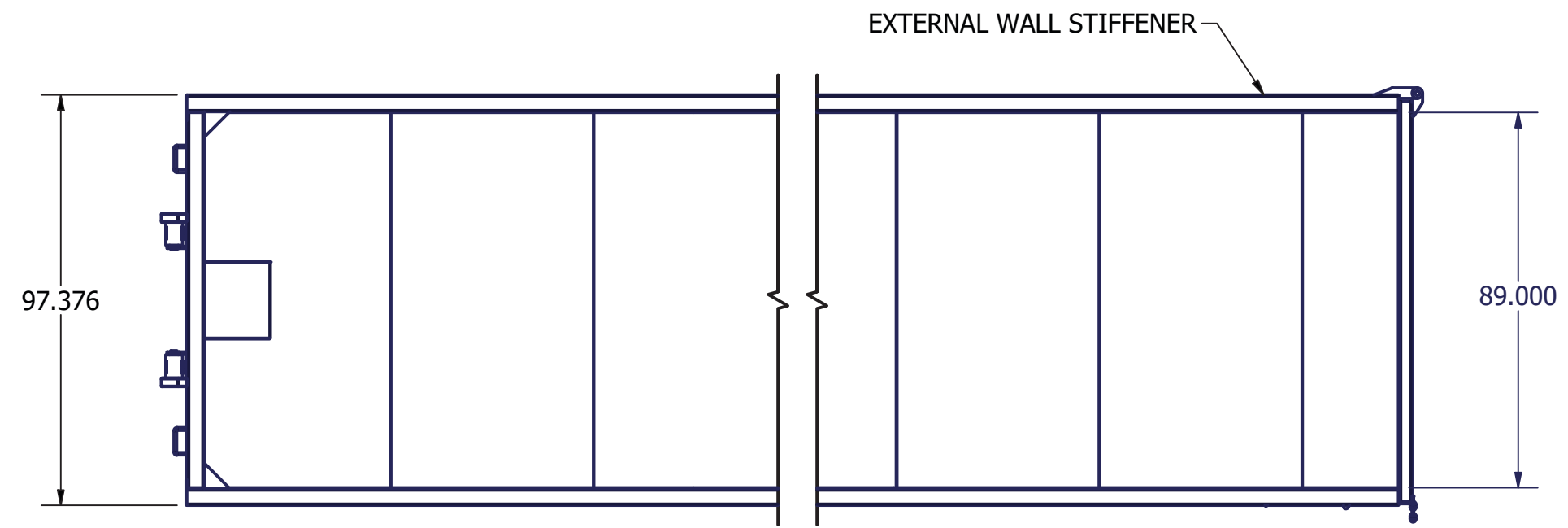

**INLAND STEEL
PRODUCTS**

- 3/16" WALLS PANELS
- 11GA BODY UPRIGHTS
- 11GA REAR UPRIGHTS
- 3/16" FLOOR PLATE
- 3" CHANNEL FLOOR
- FLA 0375X2000 SKINS
- 2"X6"X3/16" TUBE SKIDS
- 4"X3"X3/16" TUBE RAILS
- 4"X3"X3/16" DOOR FRAME
- DOOR PIPE 1.5XSCD80
- GREASEABLE 8"X10" HD RR RLR
- GREASEABLE 4"X6" FR RLR w/TIE-IN
- ADDED TIE-IN AT HOOK & PLATE
- CABLE TYPE LIFT SYST
- TARP BARS ALL AROUND
- CLEAR THROUGH TUNNEL
- 2 - 5PC HINGES

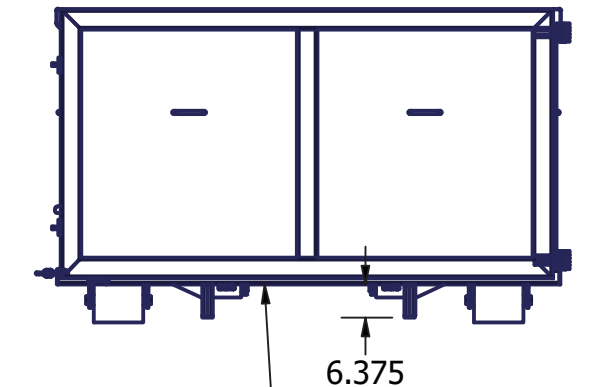
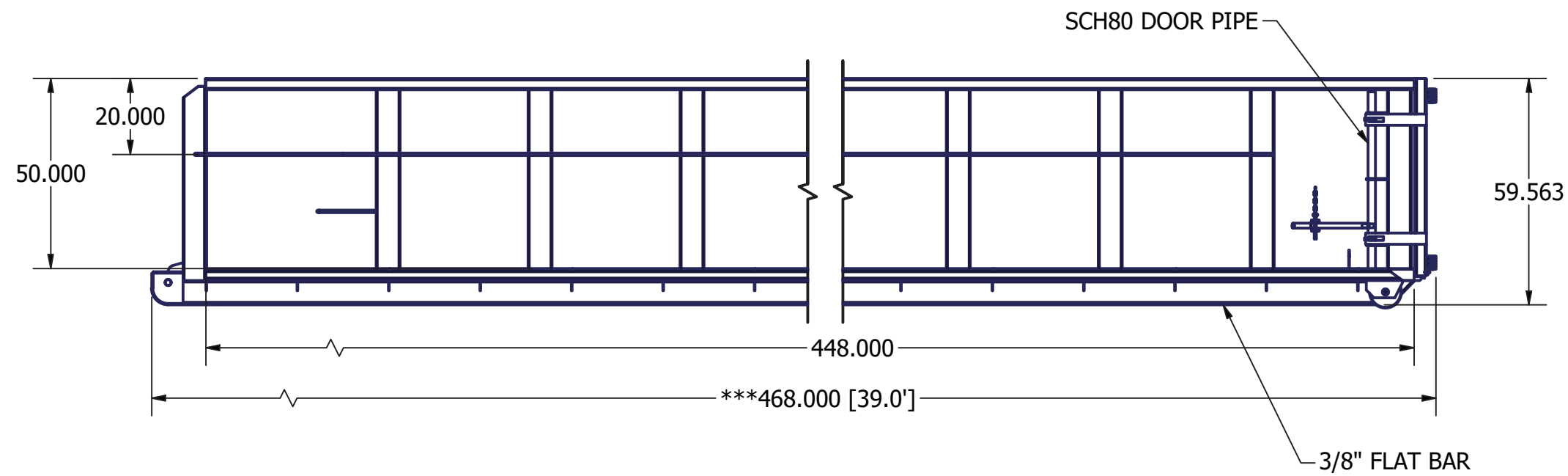
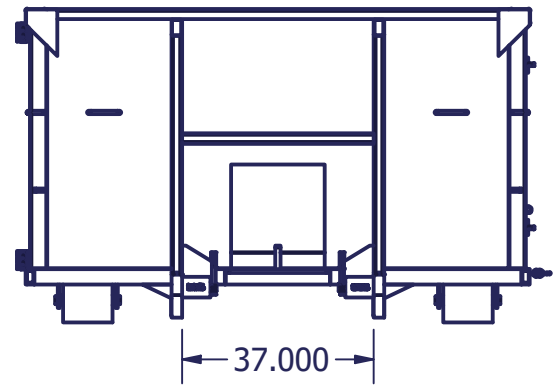
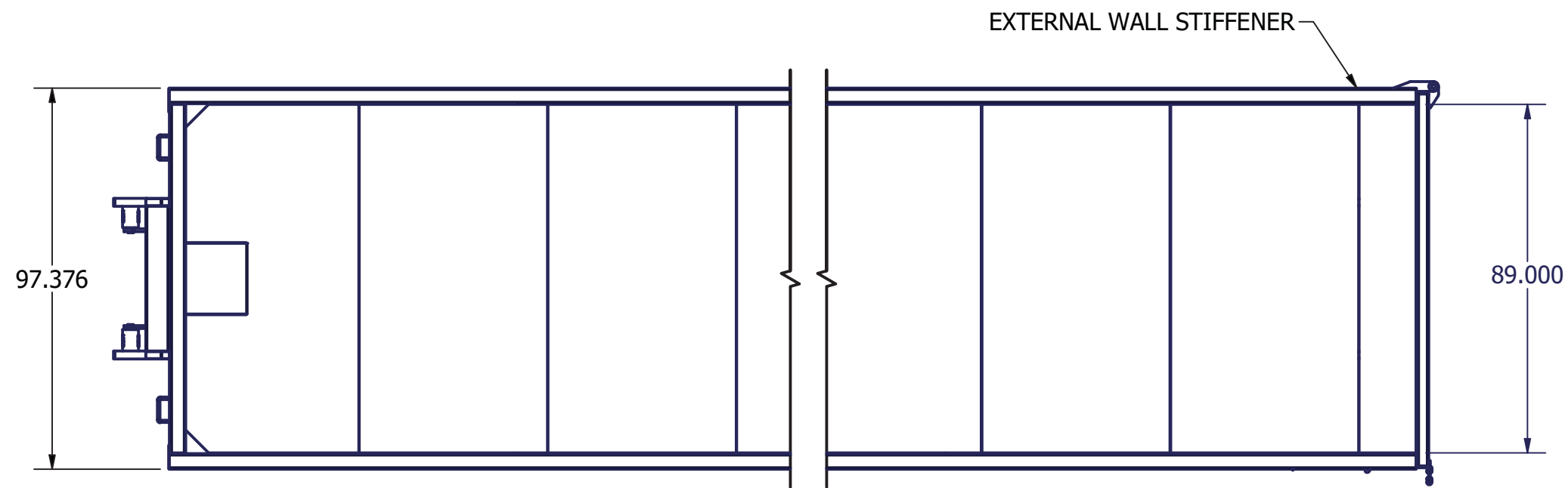

HSS3X3X250 REAR BUMPER FOR MORE CLEARANCE FOR HOIST

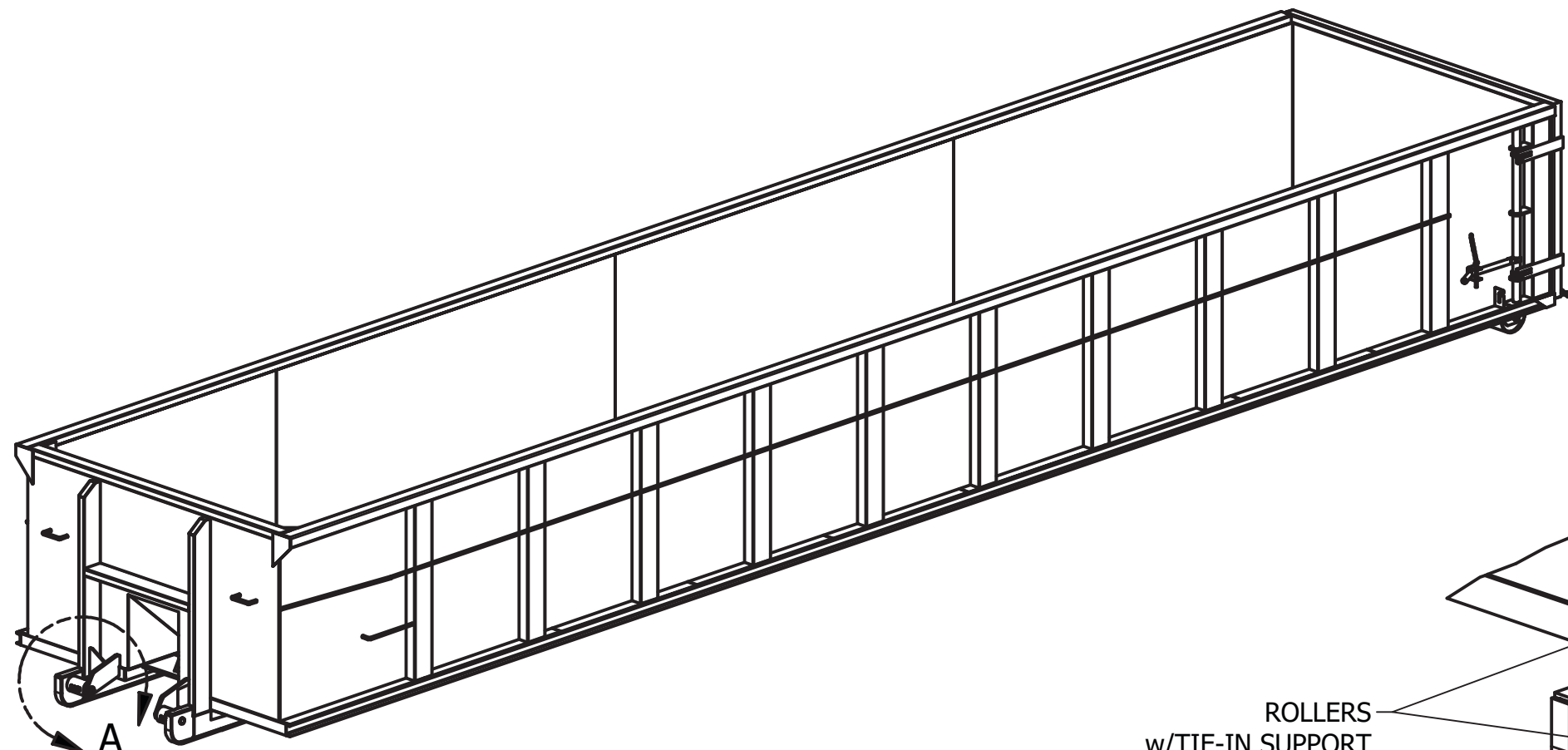

ROLLERS
w/TIE-IN SUPPORT
PLATE TO STABILIZE ROLLER

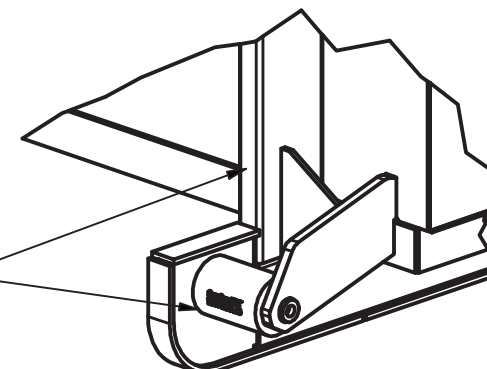

DETAIL A
SCALE .08



**INLAND STEEL
PRODUCTS**

- 3/16" WALLS PANELS
- 11GA BODY UPRIGHTS
- 11GA REAR UPRIGHTS
- 3/16" FLOOR PLATE
- 3" CHANNEL FLOOR
- FLA 0375X2000 SKINS
- 2"X6"X3/16" TUBE SKIDS
- 4"X3"X3/16" TUBE RAILS
- 4"X3"X3/16" DOOR FRAME
- DOOR PIPE 1.5XSCD80
- GREASEABLE 8"X10" HD RR RLR
- GREASEABLE 4"X6" FR RLR w/TIE-IN
- ADDED TIE-IN AT HOOK & PLATE
- CABLE TYPE LIFT SYST
- TARP BARS ALL AROUND
- CLEAR THROUGH TUNNEL
- 3 - 5PC HINGES

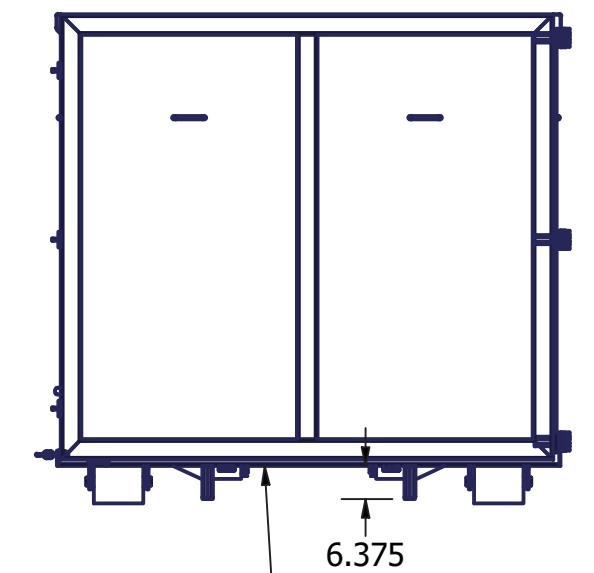
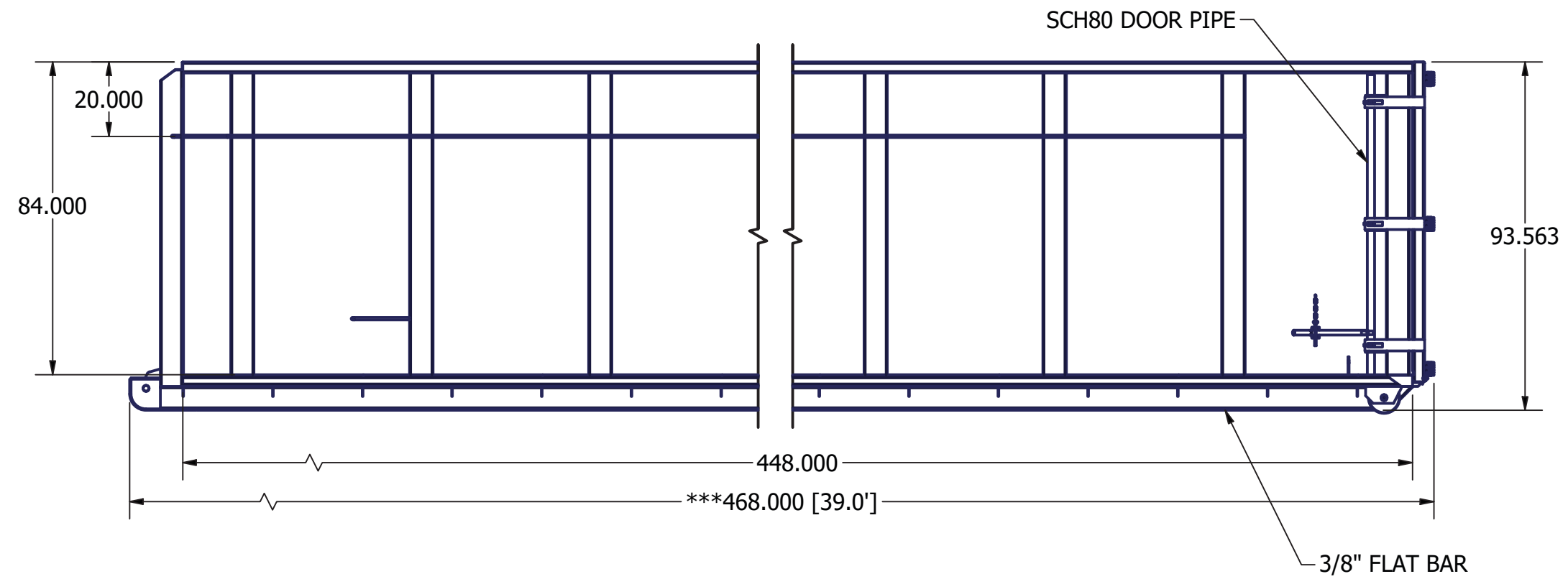
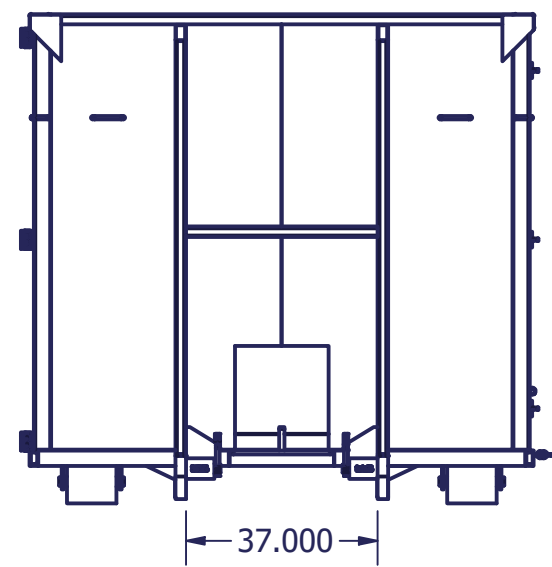
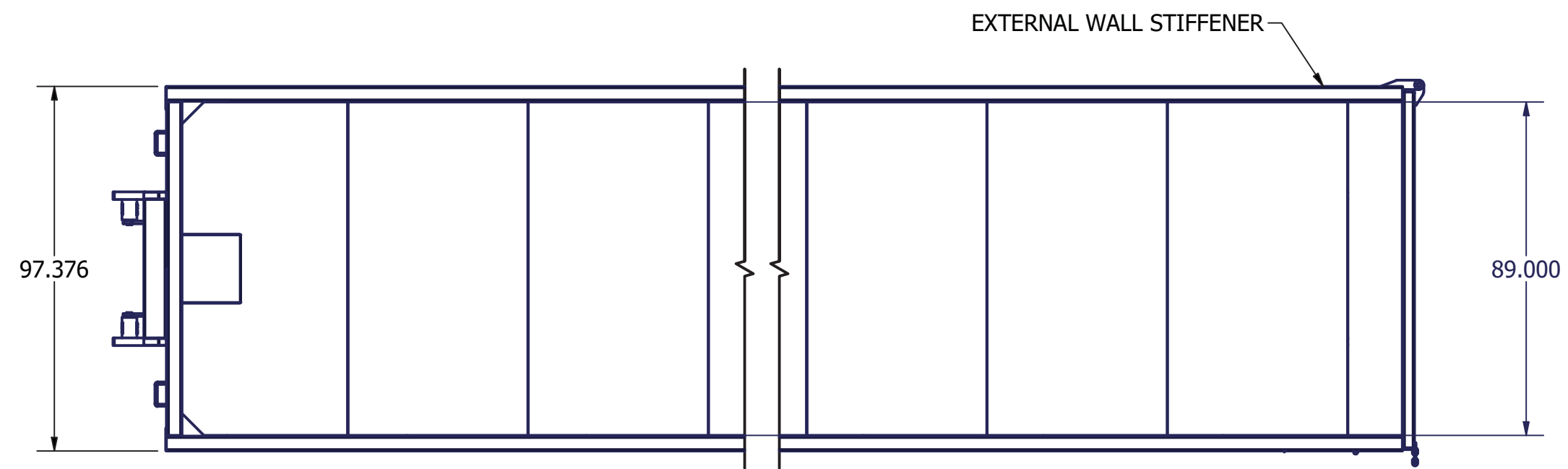

HSS3X3X250 REAR BUMPER FOR MORE CLEARANCE FOR HOIST

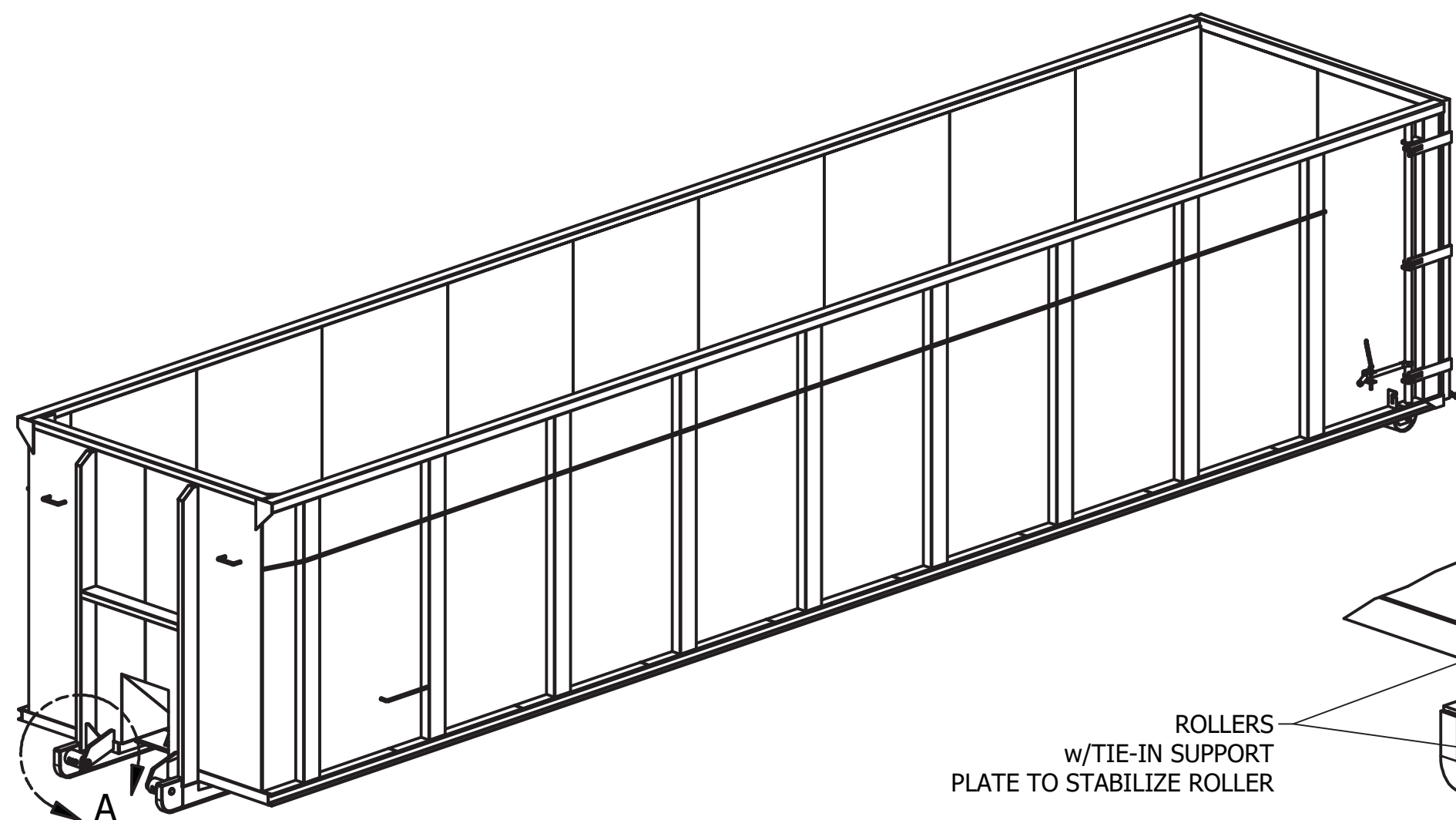

ROLLERS
w/TIE-IN SUPPORT
PLATE TO STABILIZE ROLLER

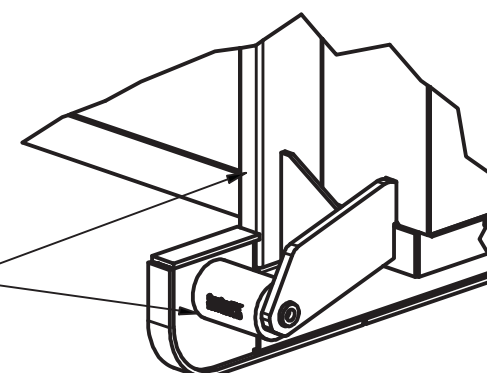

DETAIL A
SCALE .08



**INLAND STEEL
PRODUCTS**